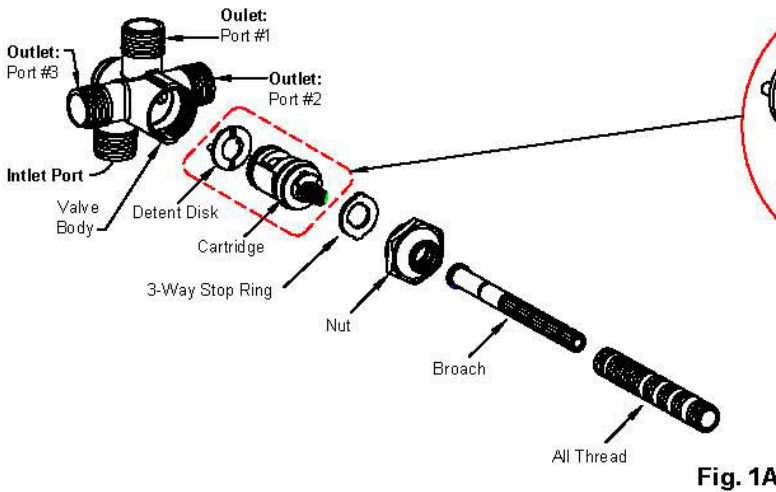

IMPORTANT

All WATERMARK DESIGNS, LTD. products are engineered to provide quality performance provided they are installed and operated properly. To fully enjoy the comfort, safety, and reliability of your new Wall Diverter Valve, please follow the instructions below.

Watermark Designs reserves the right to make modification and specification changes at any time. Please visit www.watermark-designs.com for most current technical data.

**Fig. 1A**

Inlet/Outlets: 1/2" NPT Male (or) 1/2" Copper Sweat.

Fig. 2A

**Supplied on unit
3-Way Installation**

Fig. 2B

**Extra if needed for
2-Way Installation Left**

Fig. 2C

**Extra if needed for
2-Way Installation Right**

Wall Diverter Installation

- Diverter valve has the capability for 3 port / 4 mode or 2 port / 3 mode operation.
- Inlet is located at the back and bottom of the valve with an arrow for inlet identification. The outlets are also marked with numbers 1, 2, and 3 respectively.

Connection types: NPT Thread (or) copper sweat "solder"

-For solder connections either directly to the valve, or within 6" of the valve, the **CARTRIDGE MUST BE REMOVED** from the body. When soldering do not apply excessive heat directly to the body. **Failure to follow these directions can cause damage to the body, detent disk and or cartridge, and may nullify the warranty.**

- Remove all thread, broach, body nut, cartridge and detent disk from valve body.
- Valve comes as standard with default 3 port / 4 mode and can be configured to 2 port / 3 mode.
- Define how many ports and modes are needed for your application and install the valve according to the inlet / outlets to meet those requirements. (See Fig. 1A & 4)
- Connect the mixed water supply to the diverter valve inlet.
- Connect the outlets to the desired number of applications. (for 3 way) use all 3 outlet ports, and for (2 way) use outlets 1 and 2 to the right, (or) use outlets 1 and 3 to the left. **Cap off any unused outlets to avoid potential water leakage behind the wall. (See Fig. 1 & 4)**
- Install adequate bracing support in the wall, and secure the diverter valve to the bracing.
- Remove the 3 way stop ring from the cartridge (See Fig. 1)
- Apply some silicone O-Ring grease to the detent disk and attach it to the bottom of the cartridge aligning the 2 pins horizontal to the outlet opening of the cartridge. (See Fig. 1B)
- Align the cartridge outlet with the top outlet and insert the cartridge into the body and gently push it all the way in so the detent disk pins fit into the holes inside the body. When fully inserted the cartridge will be recessed in the top of the valve.
- Install the stop ring according to installation type you have. (2 way stop ring) for 2 way function to the left or right) or 3 way for all outlets. (See Fig. 2A, 2B & 2C). Parts 2B & 2C are the same, but reversible for 2-Way right or left.
- Install body nut and tighten securely. Then install the broach and all thread (do not overtighten all thread onto body nut).

1	Valve Body
2	Detent Disk
3	Cartridge
4	2-Way Stop Ring
5	3-Way Stop Ring
6	Body Nut
7	Broach O-Ring
8	Broach
9	All Thread

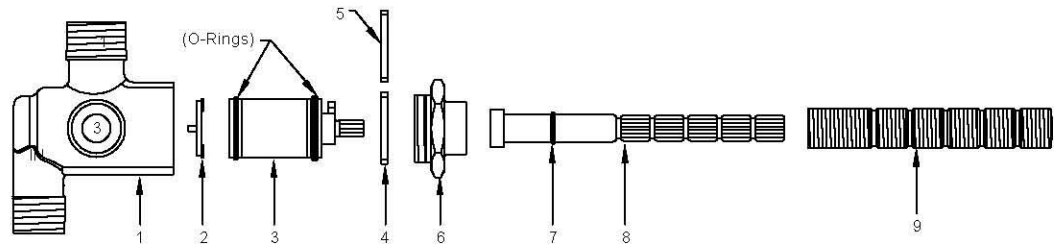
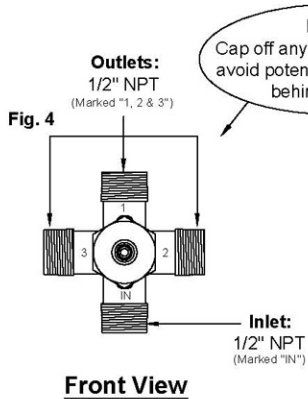
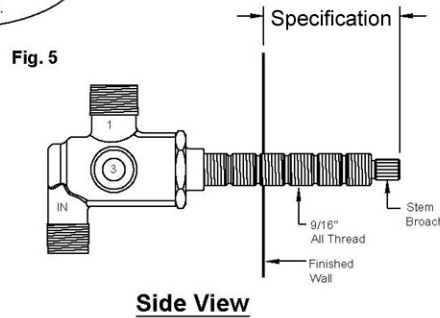

Fig. 3



NOTE:
Cap off any unused outlets to avoid potential water leakage behind the wall.



Pressure:
Maximum = 125 PSI – 8.6 Bar
Hot water supply temperature =
Maximum 185 F/ 85 C
CSA, ASSE, & IAPMO US & CA

SPECIFICATION FROM FINISHED WALL TO TIP OF BROACH STEM

HANDLE TRIM #	MEASUREMENT (IN.)	HANDLE TRIM #	MEASUREMENT (IN.)	HANDLE TRIM #	MEASUREMENT (IN.)	HANDLE TRIM #	MEASUREMENT (IN.)
A	3	CC40/ 41/ 42	2 ¼	KK	2 ¼	U3/U4/U5	3 ¼
AA	3 ¼	CC51	1 ¼	L4/ L5/ L6	1 3/4	U6/U7	3 ¼
AQ	2	CC61	2 ½	N2/ N3/ N4	2 ¼	U8	1 ¼
AX	3	CL14/ CL15	2 5/8	N5	2 ½	V	2 ¼
AZ1	2 ½	CL16	2 1/8	R1/ R2	1 ½	V1	1 ½
B4/ B5	3	CLY4	3 1/8	R3	2 ¼	V2/W	2
B9	2 1/8	CRY5	2 7/8	S	2 ¼	WA/ WB	2 ½
BB/ CC	3 1/4	D	3	S1/S1A/S2/S3	2 ¼	WC/ WD	2 ½
BL1	1 3/8	D5/ D6	2 ½	SA1	2 ¼	WW	3 ½
BL2/ BL3	1 ½	DD	3 ¼	SA2/ SW	3	X	2 3/4
BK	1 5/8	DD2/ DD3	1 7/8	T	2 ½	XJ/ XM/ XN	2"
BV01/ BV02	3	E/ F/G	3	T1/ T4	2 ½	XO/ XQ	2"
BV05	2	ED1	1 ¼	T6	3	XX	3
BV09	3	ED2/ ED3	1 3/8	T7/ T8/ T9	3	Y	2 ¼
BV13	2 ½	ED4	1 ¼	TIA/TIB	1 3/4	Y2	2 ¼
BV81	2 ¼	H	3 ¼	TR14/ TR15	3	YY	3
CC11	2 ½	H4	2 ¼	TR24/ TR25	2 1/8	Z	2 ¼
CC20/ 21/ 22	2 ¼	HH/ I	3	U	2 ½	ZZ	3
CC30/ CC31	3	IN14/IN16	3	U1	3 1/2		

NOTE: WHEN FITTING HANDLE IT MAY BE NECESSARY TO SHORTEN BROACH STEM AND/ OR THREADED NIPPLE TO MINIMIZE GAP BETWEEN HANDLE AND ESCUTCHEON

TROUBLE SHOOTING

1. Leak at body nut, and or between broach and sleeve.	The Cartridge O-ring is damaged. To replace the O-ring, remove trim, body nut, then the cartridge.
2. While using one outlet, there is water leaking from the other outlet.	Replace cartridge. The O-ring on cartridge is defective. To replace, remove all thread nipple, broach, body nut and cartridge. Fit new O-ring and apply silicone grease. Reinstall cartridge as described in the instruction sheet.