



1.0000710

PLEASE INSPECT PRODUCT AND CAREFULLY REVIEW THIS ENTIRE PACKAGE PRIOR TO INSTALLING.

These instructions do not represent step-by-step directions. They are a product supplement only to be used by a qualified/licensed plumber. We recommend all plumbing fixtures be installed by a professional.

GENERAL NOTES:

- Controller may be sited remotely up to twenty feet away from dual wheel interface. Controller requires electrical connection available within two feet of box.
- **INSTALLER MUST PROVIDE ACCESS TO CONTROLLER FOR MAINTENANCE PURPOSES.**
- We recommend installation of shut-off valves up-stream of controller to allow for maintenance.
- **NO HEAT, NO TORCH APPLIED DIRECTLY TO CONTROLLER PARTS!**
- **INSTALLER MUST FLUSH LINES PRIOR TO INSTALLING CONTROLLER. FAILURE TO INSTALL MESH FILTER PROVIDED WILL VOID WARRANTY!** An in-line water filter may be recommended in certain situations such as well water.
- Take care not to strain, staple, pinch or in any way damage the interface cables. Route cables as required to allow for replacement in case of damage. If conduit is chosen, do not place cables together with power lines or close to hot water or steam piping. Choose unobstructed route for cables to allow for ease of pulling cable and for replacement if necessary.
- Water heater must be operational for controller to function properly.

OPERATION: See enclosed booklet for operation and leave for homeowner's future reference.

Figure1

Controller Interface Mounting Details

EXPLODED VIEW

Extension sleeve to be threaded into copper mounting bracket. Control to be threaded into sleeve. Sleeve may be cut from unthreaded end only.

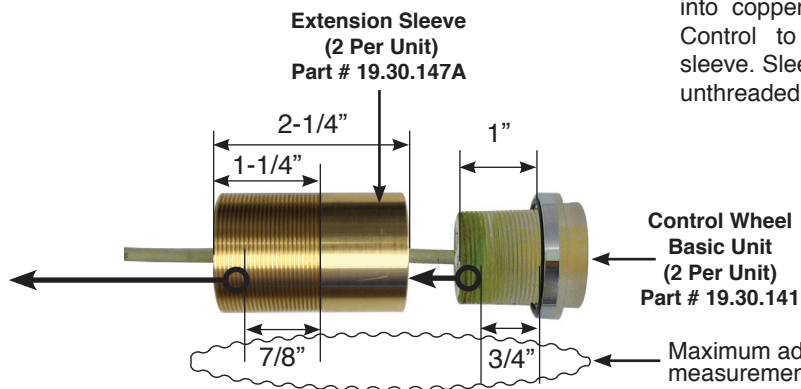
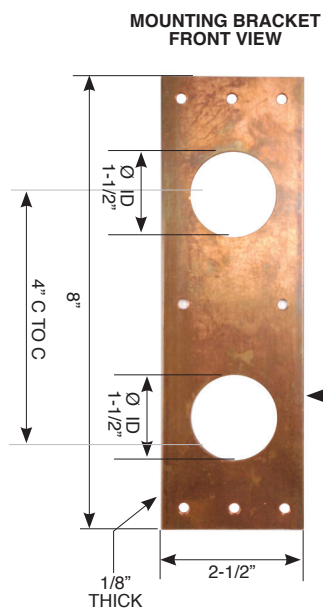

Mounting Plate can be mounted horizontally or vertically and may be cut to allow custom spacing of controls. Secure both ends of bracket to prevent movement.
Note: If installing the double back plate, the controls must be mounted vertically.

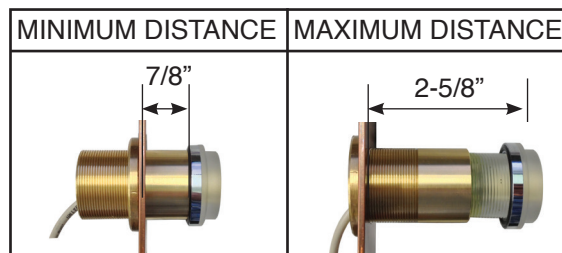

MOUNTING BRACKET BACK VIEW PART # 19.30.146.WELD

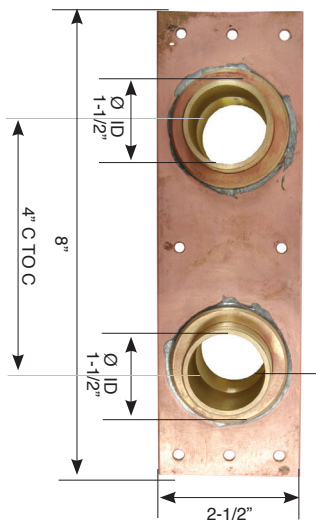

ASSEMBLED IN-WALL SIDE VIEW

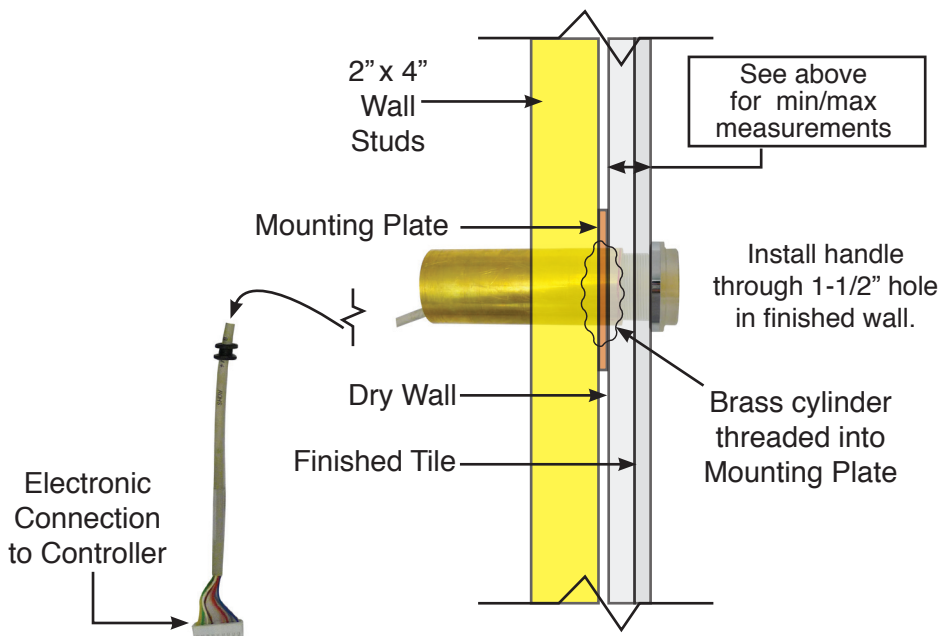
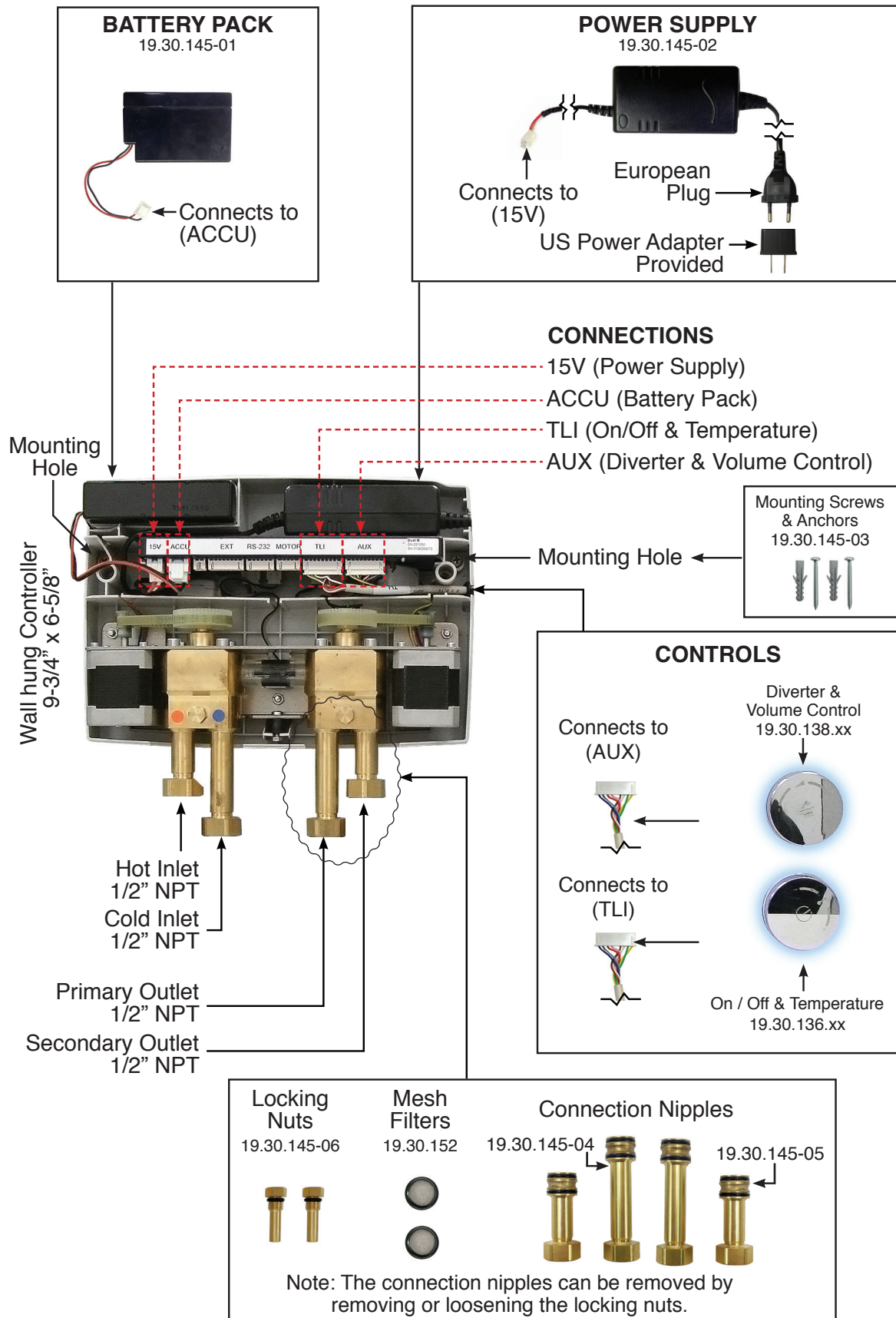
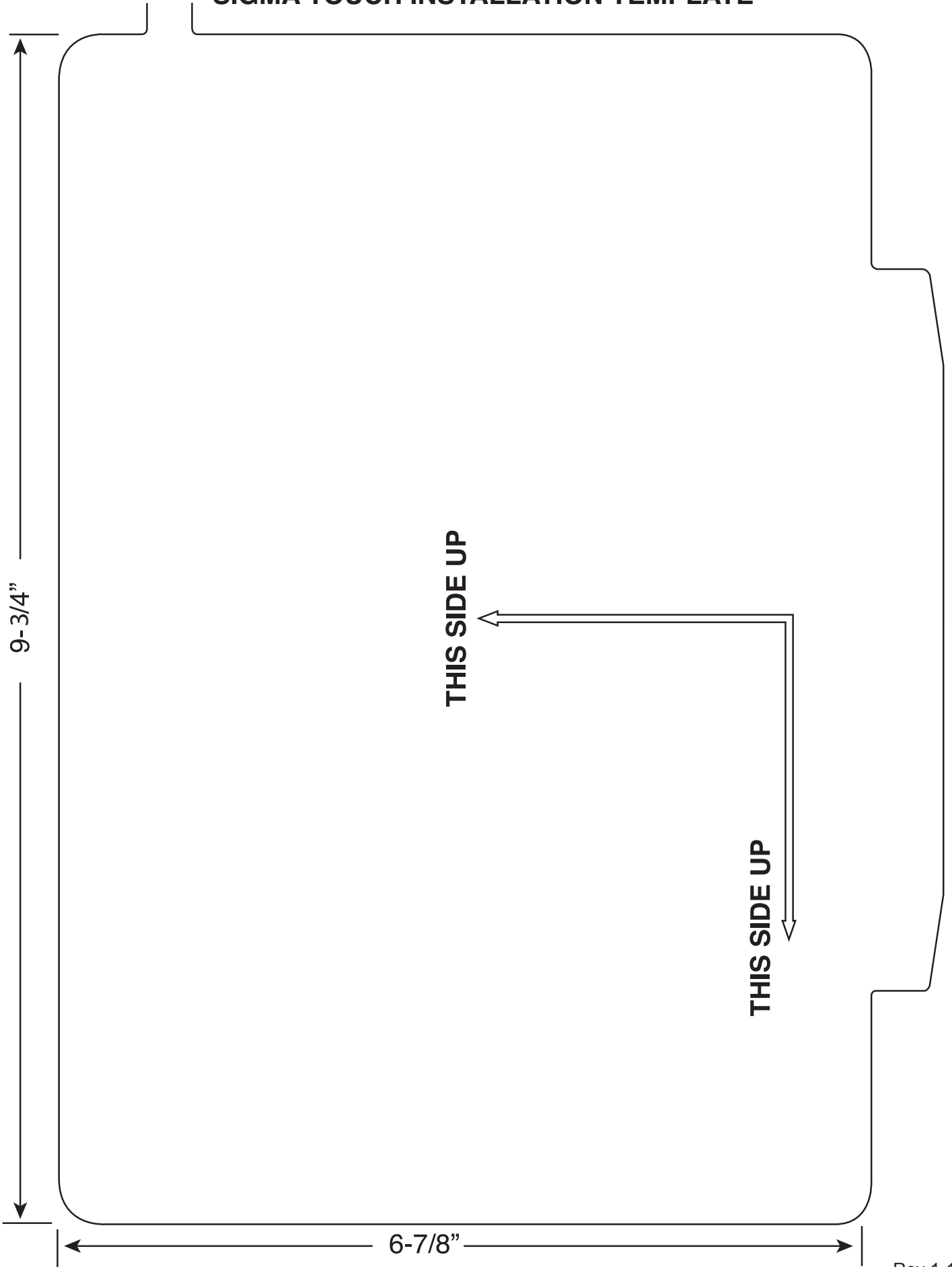

Figure 2



SIGMA TOUCH INSTALLATION TEMPLATE



**AMERICAN FAUCET & COATINGS CORPORATION
LIMITED PRODUCT WARRANTY**

Product/Finish Warranty: American Faucet & Coatings Corporation warrants that products are free from defects in materials and workmanship for five (5) years from date of invoice. In addition, our Finish Warranty provides limited LIFETIME coverage for Chrome & PVD finishes, five (5) years for Omega powder coated finishes & Polished Gold. Living finishes are warranted for workmanship only. If any material proves to be defective after inspection by our company, it will be repaired or replaced at our discretion at no charge. However, no claims for labor, shipping costs, or consequential damages will be accepted.

What we will do: We will restore any product whose finish proves to be defective back to its original finish at no charge during the appropriate warranty period stated above. Proof of purchase must be provided. After the warranty period, American Faucet and Coatings Corporation will refinish any of its faucets at the prevailing appropriate charge.

What you must do: The faucets must be properly installed according to our instructions and specifications and are for residential use only. The faucets cannot be altered in any way. You must maintain and clean the faucets in accordance with the instructions provided with the product.

How to obtain service: Send your name, address, and telephone number along with a statement describing the nature of the problem and your paid sales slip or other proof of purchase to:

**American Faucet & Coatings Corporation
3280 Corporate View
Vista, CA 92081
1-800-960-2284**

We will then contact you and take appropriate action. Do not send us any part(s) of your faucet(s) or its various connecting hoses unless we have contacted you and have sent you an approved RGA form. All transportation charges for returned goods must be paid by the customer.

What is not covered: This warranty does not cover the crystal/glass, or porcelain products of any faucet or the drain assembly or aerator on other than the Chrome or PVD finishes. This warranty also does not cover damage caused by accident, alterations, misuse, abuse, normal wear and tear, lime deposits, direct exposure to salty air or corrosive materials, or the color change that takes place with the passage of time, or use in any manner contrary to American Faucet and Coatings Corporation's printed instructions. In the case of in-the-wall installations American Faucet and Coatings Corp. will assume no liability if there is no access. **In no event will we be liable for labor of any kind, incidental or consequential damages.** This warranty is extended in lieu of all other expressed or implied warranties, whether oral or written. **Many installation compounds are harmful to brass and metal finishes. The use of any lead-based or acidic curing adhesive, silicone, mastic, or plumber's putty on or near our finished products will void the finish warranty. Use only sealants which are neutral curing and are not reactive with metal and brass finishes.** American Faucet & Coatings Corporation reserves the right to change, modify or alter its products as deemed necessary. This warranty supersedes any other American Faucet & Coatings Corporation warranties, whether oral or written.

Unless otherwise contrary to state law governing the purchase, American Faucet and Coatings Corporation's liability will not exceed the wholesale price for the American Faucet and Coatings Corporation product considered defective. This warranty gives you specific legal rights, and you may also have other rights which vary from state to state. Some states do not allow exclusion of incidental or consequential damages, so the above limitation may not apply to you.

LIFETIME WARRANTY ON 1/4 TURN CERAMIC DISC CARTRIDGE

Should the ceramic disc cartridge in your faucet ever fail, American Faucet & Coatings Corporation will replace the failed part free of charge to the original purchaser of the product. Your cost will be a \$10.95 handling and mailing charge. Labor not included. When ordering replacements, denote for widespread or centerset lavatory, Roman Tub, or other. Include age of faucet. (This does not include thermostatic, pressure balance, or diverter cartridges.)

NOTICE

American Faucet & Coatings Corporation products are ICC-PMG listed and are tested to ASME A112.18.1M and ASSE 1016, and comply with Section 9 of NSF 61 for basin faucet, bar faucets, and kitchen faucets as required.