

FEATURES:

- Mounting brackets and screws are supplied.
- Warranty varies according to finish selection
- Certified to meet or exceed the following codes and standards:
ASME A112.18.1/CSA B 125.1-2012

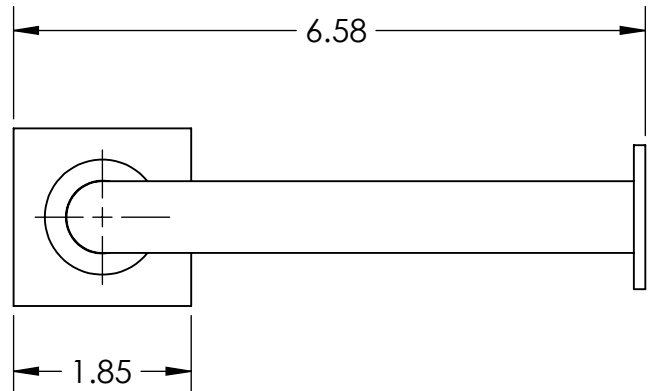
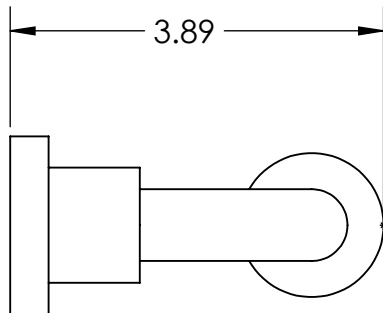
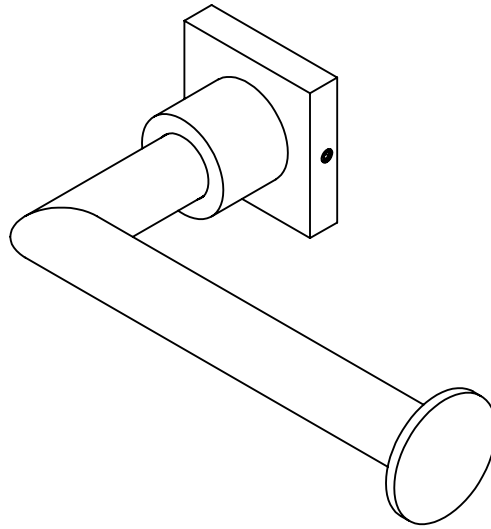

Note: Measurements are subject to change or cancellation. No responsibility is assumed for use of superseded or voided pages.