

Granite Composite
 Premium Granite Composite
 Dual-mount Kitchen Sink

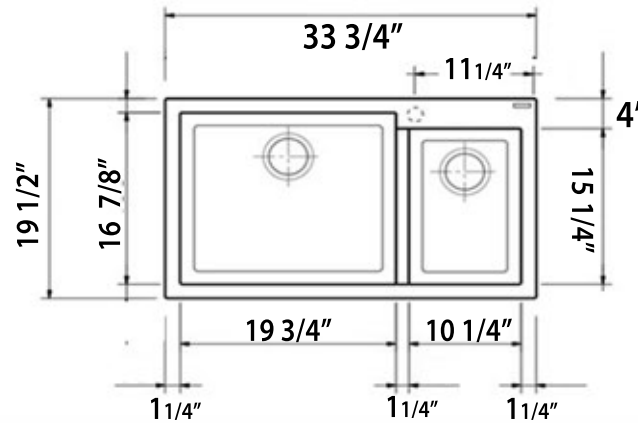

MODEL:
PR7030-TI



1 PRE-DRILLED CENTER HOLE
 AS SHOWN IN PRODUCT IMAGE

ADDITIONAL HOLE POCKETS
 AVAILABLE ON BACK SIDE OF SINK

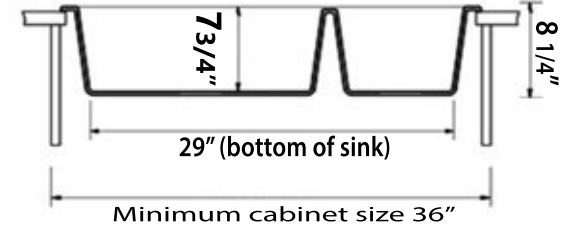

Minimum cabinet size 36"

Overall Dimensions	Interior Bowls	Bowl Depth	Height	Drain Holes
33.25" x 19.5" top 29" x 16.25" bottom	19.75" x 16.875" 10.25" x 15.25"	7.75"	8.25" Overall	3.5"

FEATURES

- Premium Granite Composite Kitchen Sink
- 80% Stone/20% Resin
- Scratch Resistant/Heat resistant to 560F degrees
- Hygienic non-porous surface
- Topmount Installation
- Designed and made in Italy
- Product weight: 30lbs.
- Limited Manufacturers Warranty



PROJECT/ NAME:

ARCHITECT/CONTRACTOR:

MODEL:

JOB NOTES: