

NOTES:

1. APPLY PERMANENT THREAD LOCKER (LOCTITE 680)

2. BAG ITEMS 1 AND 3. ASSEMBLE ALL REMAINING ITEMS.

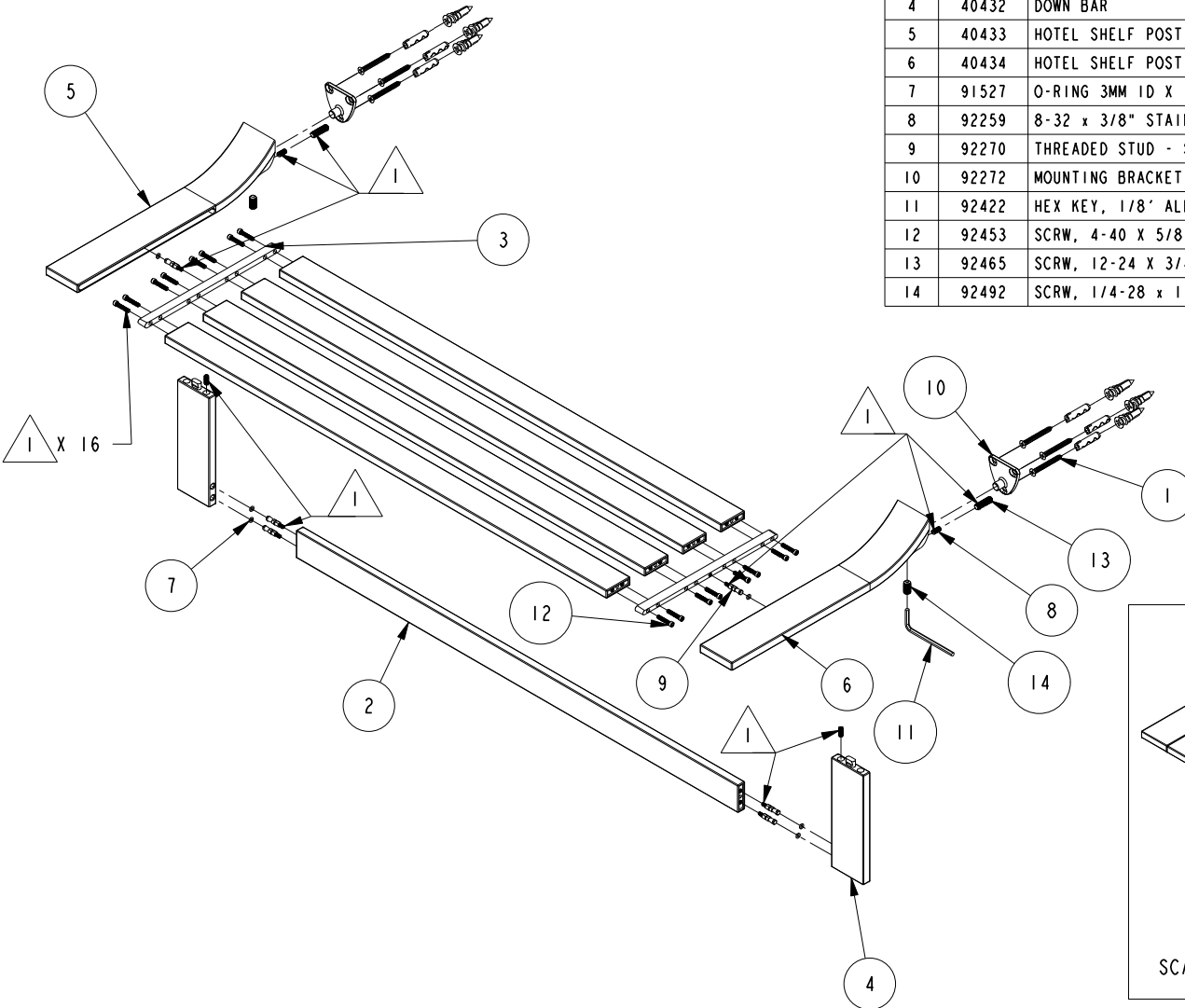

BILL OF MATERIAL (CURRENT LEVEL)

ITEM	PT/ASSY	DESCRIPTION	TYPE	QTY.
1	1-229	HOTEL SHELF HARDWARE PACK	ASSEMBLY	2
2	7-692	TOWEL BAR AND INSERT ASSY	ASSEMBLY	5
3	40427	SIDE RAIL-LONG	PART	2
4	40432	DOWN BAR	PART	2
5	40433	HOTEL SHELF POST W/TOWEL BAR LEFT	PART	1
6	40434	HOTEL SHELF POST W/TOWEL BAR RIGHT	PART	1
7	91527	O-RING 3MM ID X 1MM WIDTH BUNA-N, SHORE A 70 (MMC# 9262K441)	PART	6
8	92259	8-32 x 3/8" STAINLESS STEEL SET SCREW	PART	4
9	92270	THREADED STUD - SHORT	PART	6
10	92272	MOUNTING BRACKET	PART	2
11	92422	HEX KEY, 1/8" ALLOY STEEL (MMC# 7122A18)	PART	1
12	92453	SCRW, 4-40 X 5/8" HEX SKT HD CAP, Zn PLATED (MMC #92196A112)	PART	16
13	92465	SCRW, 12-24 X 3/4" CUP POINT SOCKET SET SCREW	PART	2
14	92492	SCRW, 1/4-28 x 1/2" CUP POINT SET SS (MMC # 92311A560)	PART	2

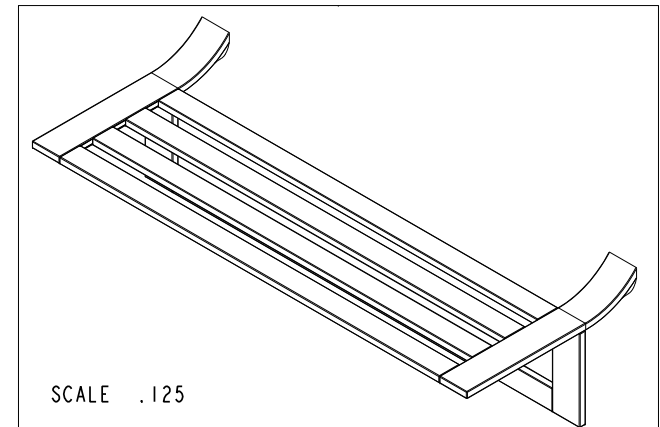

COPYRIGHT 2005 GINGER. THESE DRAWINGS AND THE DESIGNS DEPICTED HEREIN ARE THE PROPRIETARY PROPERTY OF GINGER. ANY USE OR REPRODUCTION IS SUBJECT TO THE EXPRESS APPROVAL OF GINGER. UNAUTHORIZED USE IS STRICTLY PROHIBITED. ALL RIGHTS RESERVED.

GINGER

2001 E. CARNEGIE AVE.
SANTA ANNA CA 92705
(949) 417-5207

24" HOTEL SHELF

ASSY. NO. 4743-24

SCALE .156

REF. -

SHEET 1 OF 2

C	EN-1718	03/29/11
B	EN-1701	02/17/11
A	EN-1683	01/06/11
-	EN-1294	11/09/10
REV	REV DESC	DATE

SPECIFICATION DWG

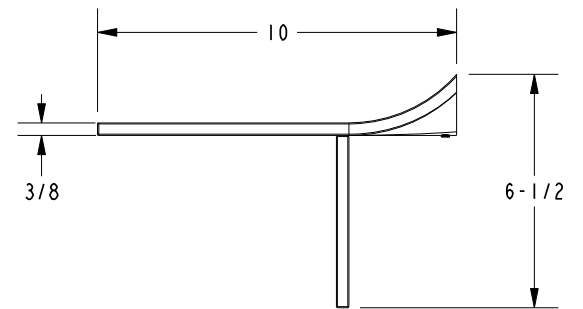
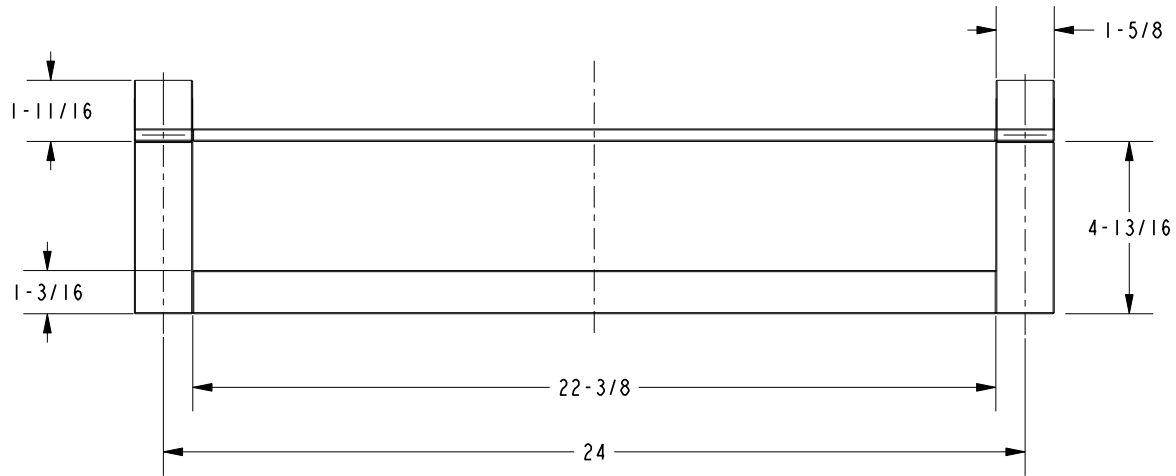
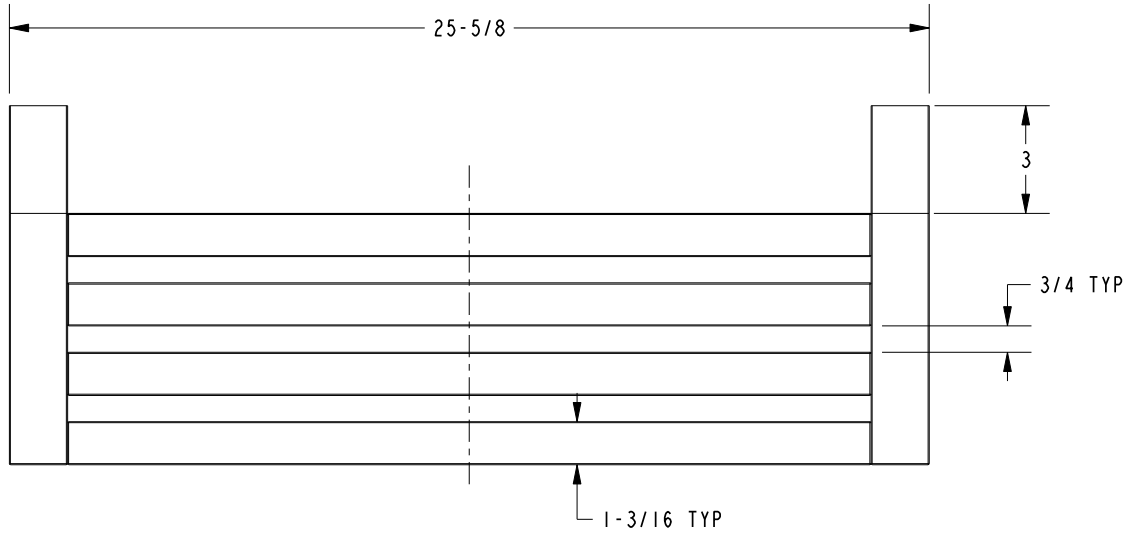

DIMENSIONS ARE IN INCHES AND AN APPROXIMATION OF A TYPICAL INSTALLATION

COPYRIGHT 2005 GINGER. THESE DRAWINGS AND THE DESIGNS DEPICTED HEREIN ARE THE PROPRIETARY PROPERTY OF GINGER. ANY USE OR REPRODUCTION IS SUBJECT TO THE EXPRESS APPROVAL OF GINGER. UNAUTHORIZED USE IS STRICTLY PROHIBITED. ALL RIGHTS RESERVED.

GINGER		2001 E. CARNEGIE AVE. SANTA ANA CA 92705 (949) 417-5207	
DWG NO.	4743-24	REV	C
SCALE	.187	REF.	-
		SHEET	2 OF 2