

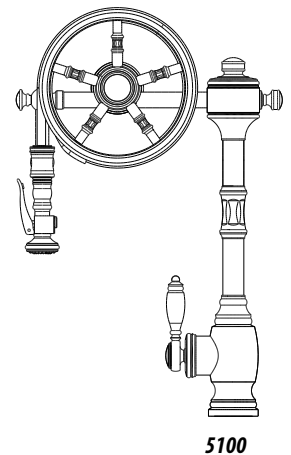

WHEEL PULLDOWN FAUCET INSTALLATION INSTRUCTIONS

Wheel Model #s:
5100



★ MADE IN AMERICA ★

BEFORE YOU BEGIN YOUR INSTALLATION:

1



Turn off water supply.

2



Observe all local plumbing codes.

3

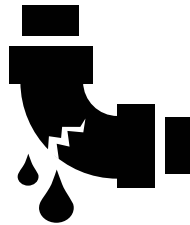

Inspect waste and water supplies for signs of damage. Replace as necessary.

4



DO NOT use petroleum based products on this faucet.

REQUIRED TOOLS:



1. Adjustable Wrench



2. Phillips Screwdriver

PARTS INCLUDED:

**XX represents finish*

HK-THC-XX*
TRADITIONAL HANDLE CAP KIT

HK-USM1375
UNDER SINK MOUNTING HARDWARE KIT (1-3/8")

LIFETIME WARRANTY

All Waterstone products manufactured by Waterstone carry a **Limited Lifetime Guarantee** against functional defect in material or workmanship in a residential application. Consult with an authorized Waterstone dealer for complete information about our warranty.

For any questions or concerns about your faucet's warranty, contact Waterstone.

Waterstone Faucets
41180 Raintree Court • Murrieta, CA 92562
1-888-304-0660
www.waterstoneco.com

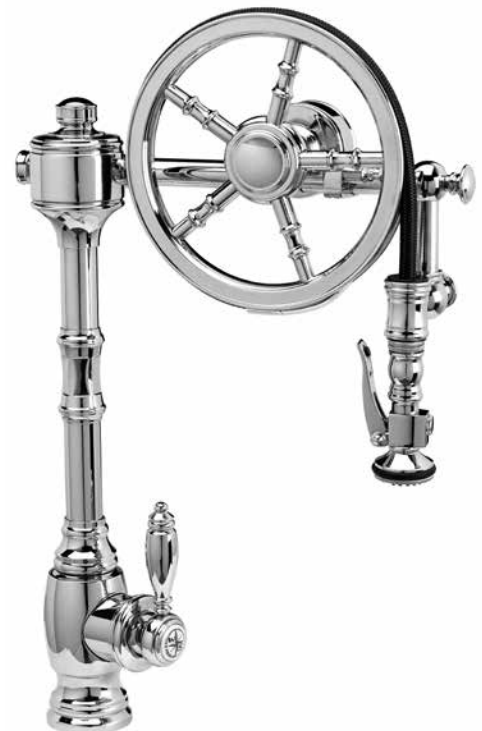

WHEEL FAUCET INSTALLATION

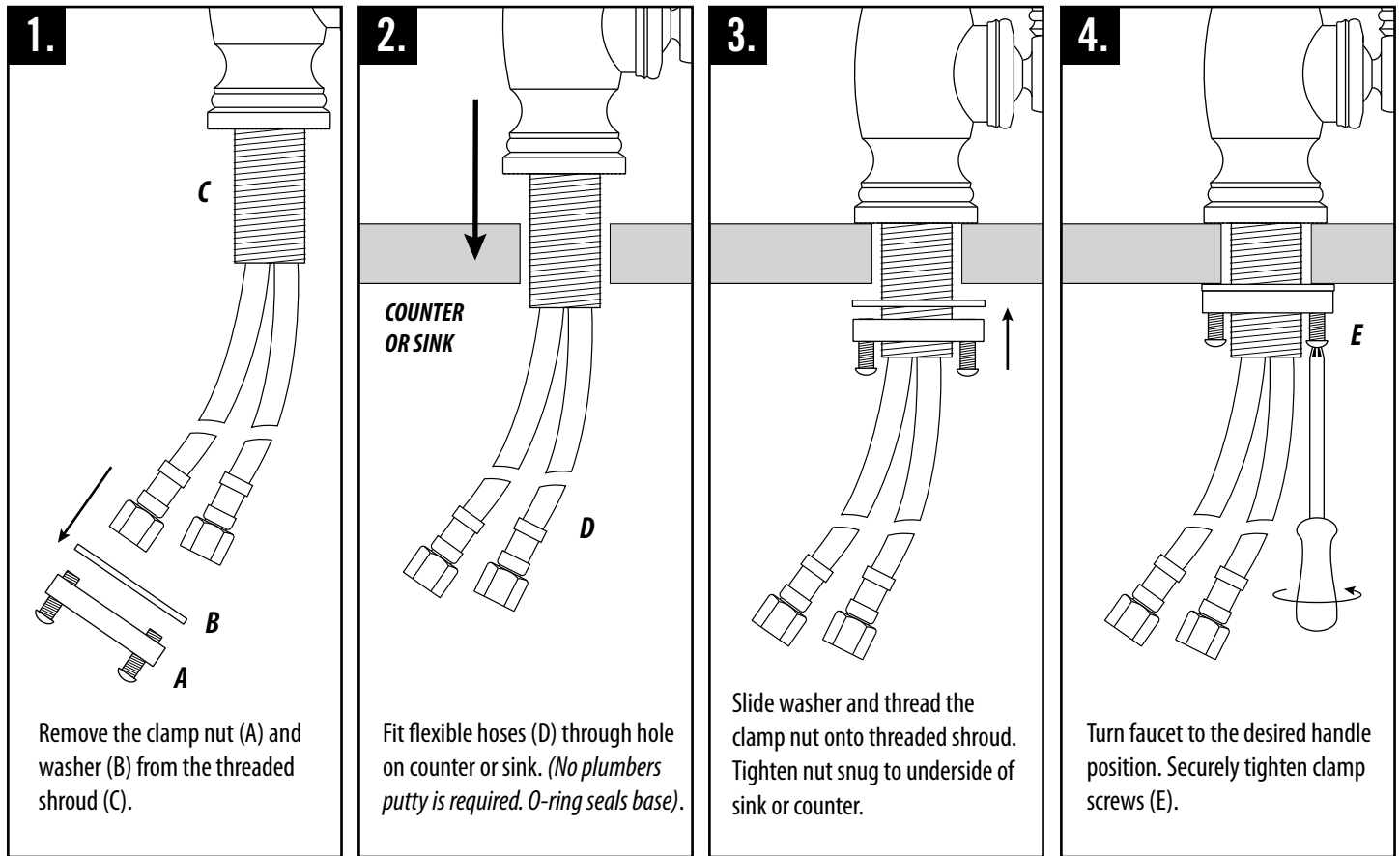

HANDLE POSITION

Waterstone faucets are designed for 3 different faucet positions. Handle on left, front and right. Your faucet is configured for the most common installation (see right). To reverse this and have the handle positioned on the left, connect the hose for cold water to the hot supply and the hose for hot water to the cold supply. This will maintain the relationship of pulling the handle for hot water or pushing for cold water.

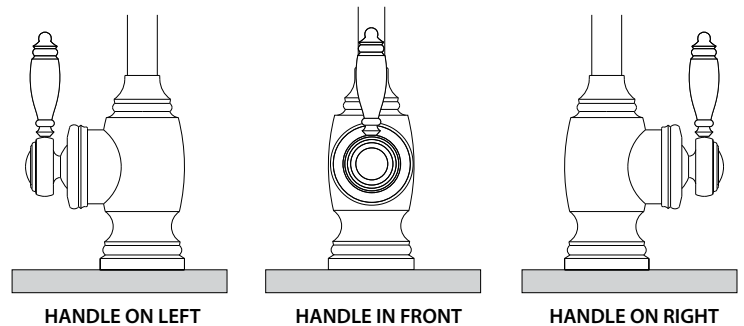

OPTIONAL DECORATIVE CAPS
(3 INCLUDED)

- To remove, place a small standard screwdriver in the slot at the bottom of metal ring that surrounds the handle caps. Gently pry the cap from faucet handle.
- To replace, position cap and snap in with thumb.

CONNECTING SUPPLY HOSES

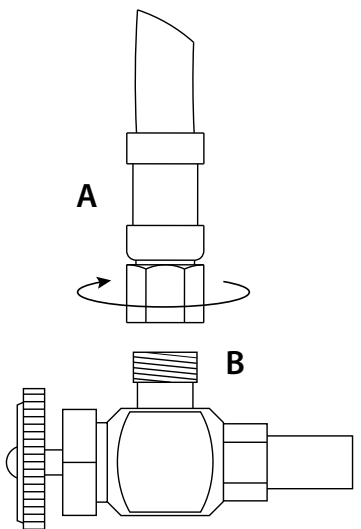

1. Before connecting supply hoses, flush supply stops to clear any debris. Place a bucket underneath stops and run water for 5 to 10 seconds. Turn water off.
2. Carefully position hot and cold supplies so they will not interfere with other hoses.
3. Connect supply hoses (A) to supply stops (B). **DO NOT** use teflon tape, plumbers tape or plumbers putty. Turn water back on and check for leaks.

ADJUST HANDLE POSITION AND HANDLE TENSION

On some kitchen countertops, the handle may hit the backsplash when the faucet handle is positioned to the left or right (Fig. 1). Waterstone gives you the option of adjusting the handle 45 degrees to avoid hitting backsplash.

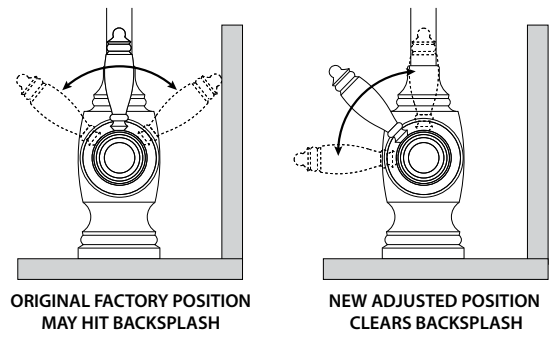
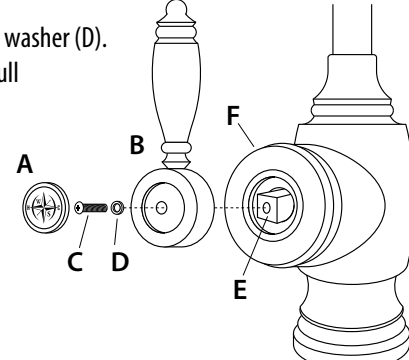
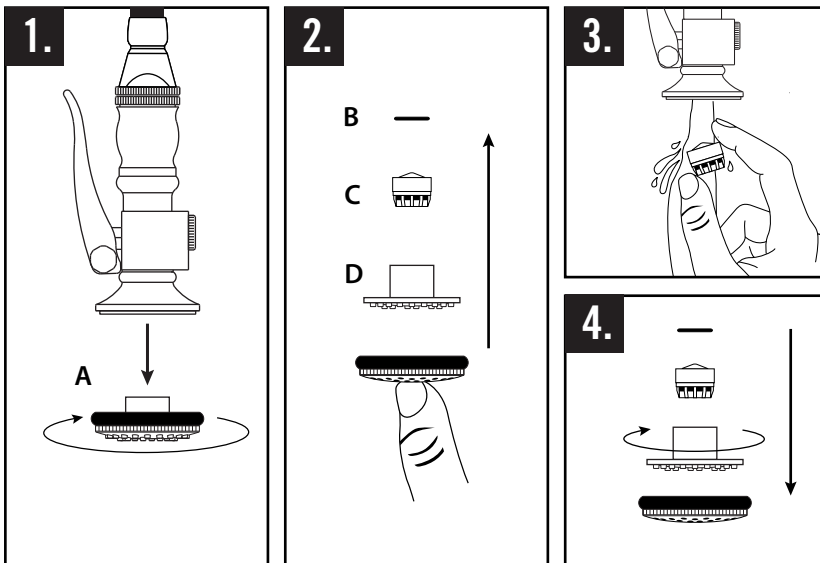

FIG.1

1. Place a small standard screwdriver in the slot at the bottom of metal ring that surrounds the handle caps (A). Gently pry the cap from faucet handle (B).
2. Unscrew and remove holding screw (C) and washer (D).
3. Hold the handle (B) in a vertical position. Pull straight off faucet. Rotate handle away from backsplash then slide handle back onto valve stem (E).
4. Insert holding screw with washer and tighten. Snap handle cap back into place.
5. To adjust handle tension, turn ring (F) clockwise to increase or counterclockwise to decrease handle tension.



CLEANING AERATOR



- 1.
- 2.
- 3.
- 4.

1. Gently unscrew and remove spray face (A) by hand.
2. To remove O-ring (B), aerator (C) and spray face insert (D), push with finger from bottom.
3. Thoroughly rinse aerator with water until all debris is removed.
4. Place spray face insert back into spray face and spin until it clicks into place. Next, place aerator and O-ring into spray face. Gently screw spray face, by hand, snugly back onto sprayer.

DEBRIS SCREEN FEATURE

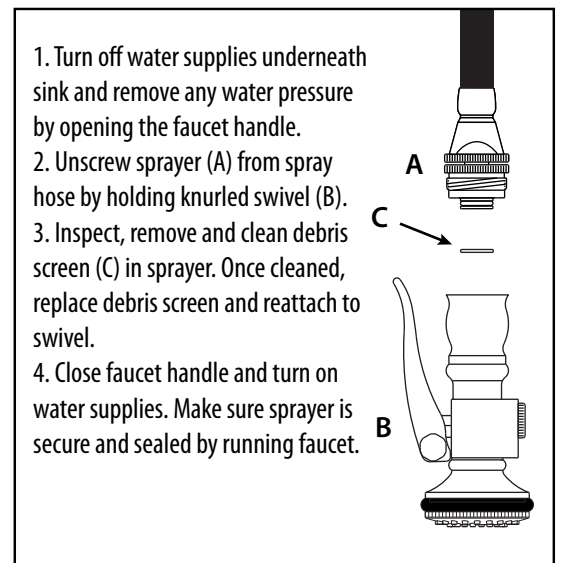

1. Turn off water supplies underneath sink and remove any water pressure by opening the faucet handle.
2. Unscrew sprayer (A) from spray hose by holding knurled swivel (B).
3. Inspect, remove and clean debris screen (C) in sprayer. Once cleaned, replace debris screen and reattach to swivel.
4. Close faucet handle and turn on water supplies. Make sure sprayer is secure and sealed by running faucet.

CARE AND CLEANING FOR WATERSTONE FAUCET FINISHES

ATTENTION: Waterstone offers many finishes for its faucet product line. Every finish is unique and requires different techniques of care and cleaning. Find your faucet's finish in sections below, then carefully read and follow directions for that finish.

ABOUT YOUR FINISH:

These finishes have a clear protective coating on them. Even though they have a protective coating, they are only considered semi-durable. If the outside clear coating is scratched or damaged in any way, the base metal finishes exposed will oxidize. Any use of an abrasive cleanser, or any abrasive pad, cloth or sponge can remove or dull the protective coating and damage the finish. Some available sink cleaners with bleach, soaps, and hand lotions will damage the finish, as can acidic organic cleansers. Always wipe your fixture down with a clean soft cloth and keep it clean and dry after use.

IMPORTANT NOTICE:

It is the responsibility of the customer to check for any material finish defects **BEFORE** installation.

SUGGESTED FINISH MAINTENANCE PROCEDURE:

1. Do not allow water spots to dry on the fixture. Keep the surface clean and dry after use.
2. Periodic cleaning can be done by using a mild diluted glass cleaner (we recommend Windex). Apply the mild cleaner to a soft clean cloth, and periodically wipe your fixture down to remove water spots and surface debris.
3. Never use cleaners with bleach, abrasives, or vinegar. Never use any type of abrasive pad or sponge.

Antique Brass - AB
Antique Copper - AC
American Bronze - AMB
Antique Pewter - AP
Black Nickel - BLN
Distressed Antique Brass - DAB
Distressed Antique Copper - DAC
Distressed American Bronze - DAMB
Distressed Antique Pewter - DAP
Polished Brass - PB
Polished Copper - PC
Polished Nickel - PN
Satin Nickel - SN
Venetian Bronze - VB

ABOUT YOUR FINISH:

These finishes are considered Living Finishes and have **NO PROTECTIVE COATING** on them. Living finishes are finishes that have a very shallow patina on their surface. Essentially, the finish is what nature would do to the surface over a long period of time. The finishes are intended to change with time and generally darken slightly where they are not being touched, and highlight where the high use points are on the fixture. Hand oils, soaps, and acidic fluids and cleaners can damage the finish. These finishes are not durable, and are easily scratched or scuffed. Any type of astringent cleaner or any type of abrasive cleanser, pad, cloth or sponge will damage the finish. To help keep the surface on the fixture from oxidizing in the packaging, Waterstone initially applies a wax to the finish surface to help protect and prevent the finish from exposure to air and oxidizing prior to installation.

IMPORTANT NOTICE:

It is the responsibility of the customer to check for any material finish defects **BEFORE** installation. Waterstone does not warranty these finishes **AFTER** the fixture has been installed.

SUGGESTED FINISH MAINTENANCE PROCEDURE:

1. Do not allow water spots to dry on the fixture. Keep the surface clean and dry after use.
2. Periodic cleaning can be done by using a micro-crystalline wax (we recommend Renaissance Wax). Apply the wax with a soft non abrasive tissue paper, and gently buff the wax with a soft clean cloth to help remove surface spots and add a protective coating the finish.
3. Never use cleaners with bleach, abrasives, or vinegar. Never use any type of abrasive pad or sponge.

Antique Bronze - ABZ
Caribbean Bronze - CB
Tuscan Brass - TB
Weathered Brass - WB

ABOUT YOUR FINISH:

These finishes are powder coated color finishes. They have **NO ADDITIONAL PROTECTIVE COATING**. These finishes are not considered durable finishes and can be scratched, chipped or scuffed. If the exterior color coating is damaged, the exposed metal base will oxidize. Any use of an abrasive cleanser, or any abrasive pad, cloth or sponge can remove or dull the color coating and damage the finish. Some available sink cleaners with bleach, soaps, and hand lotions will damage the finish, as can acidic organic cleansers. Always wipe your fixture down with a clean soft cloth and keep it clean and dry after use.

IMPORTANT NOTICE:

It is the responsibility of the customer to check for any material finish defects **BEFORE** installation.

SUGGESTED FINISH MAINTENANCE PROCEDURE:

1. Do not allow water spots to dry on the fixture. Keep the surface clean and dry after use.
2. Periodic cleaning can be done by using a mild diluted glass cleaner (we recommend Windex). Apply the mild cleaner to a soft clean cloth, and periodically wipe your fixture down to remove water spots and surface debris.
3. Never use cleaners with bleach, abrasives, or vinegar. Never use any type of abrasive pad or sponge.

Almond - 01
Black - 06
Biscuit - 07
Chocolate Bronze - CHB
Euro-White - EW
Matte Black - MB
White - WT

ABOUT YOUR FINISH:

Waterstone's stainless steel fixtures are actually made of solid stainless. This finish has **NO PROTECTIVE COATING** on it. Stainless steel is by its material nature very tarnish resistant, but by no means tarnish or stain proof. This finish will indeed oxidize naturally over time and react to its environment, and in a reaction to some chemical cleaners that have bleach in them rusting can be induced on the finish. Keep your stainless fixture wiped clean and dry, and use only a cleaner specifically made for stainless steel. Trapped moisture on the surface of your finish can lead to staining. Astringent cleaners, chlorine, bleach, along with acidic based organic cleansers are potentially harmful to stainless steel finishes.

IMPORTANT NOTICE:

It is the responsibility of the customer to check for any material finish defects **BEFORE** installation.

SUGGESTED FINISH MAINTENANCE PROCEDURE:

1. Do not allow water spots to dry on the fixture. Keep the surface clean and dry after use.
2. Periodic cleaning can be done by applying a "stainless steel cleaner" with a soft clean cloth to gently remove surface spots and brighten the finish.
3. Never use cleaners with bleach, abrasives, or vinegar. Never use any type of abrasive pad or sponge.

Stainless Steel - SS

ABOUT YOUR FINISH:**Weathered Copper - WC**

This finish is considered a Living Finish and has **NO PROTECTIVE COATING** on the surface. Living finishes are finishes that have a very shallow patina on their surface. Essentially, the finish is what nature would do to the surface over a long period of time. The finishes are intended to change with time and generally darken slightly where they are not being touched, and highlight where the high use points are on the fixture. Hand oils, soaps, and acidic fluids and cleaners can damage the finish. This finish is not durable, and can be easily scratched or scuffed. Any type of astringent cleaner or any type of abrasive cleanser, pad, cloth or sponge will damage the finish. To help keep the surface on the fixture from oxidizing in the packaging, Waterstone initially applies a non abrasive all purpose metal polish to the finish surface to help protect and prevent the finish from exposure to air and oxidizing prior to installation.

IMPORTANT NOTICE:

It is the responsibility of the customer to check for any material finish defects **BEFORE** installation. Waterstone does not warranty these finishes **AFTER** the fixture has been installed.

SUGGESTED FINISH MAINTENANCE PROCEDURE:

1. Do not allow water spots to dry on the fixture. Keep the surface clean and dry after use.
2. Periodic cleaning can be done by applying denatured isopropyl alcohol to a clean soft cloth and gently wiping down the finish surface to clean. Make sure not to rub too hard, in that you can remove too much of the surface patina. This step will leave the finish looking a shade darker.
3. Using a different soft clean cloth, apply a non-abrasive metal polish (we recommend "Miracle Shine" by GSM) to cloth and gently rub polish into the finish. This will clean, protect, and brighten up the finish after it was left darker from the alcohol cleaning in step 2.
4. Never use cleaners with bleach, abrasives, or vinegar. Never use any type of abrasive pad or sponge.

ABOUT YOUR FINISH:**Black-Oil Rubbed Bronze - ORB**

This finish is considered a Living Finish and has **NO PROTECTIVE COATING** on the surface. Living finishes are finishes that have a very shallow patina on their surface. Essentially, the finish is what nature would do to the surface over a long period of time. The finishes are intended to change with time and generally darken slightly where they are not being touched, and highlight where the high use points are on the fixture. Hand oils, soaps, and acidic fluids and cleaners can damage the finish. This finish is not durable, and can be easily scratched or scuffed. Any type of astringent cleaner or any type of abrasive cleanser, pad, cloth or sponge will damage the finish. To help keep the surface on the fixture from oxidizing in the packaging, Waterstone initially applies a non abrasive all purpose metal polish to the finish surface to help protect and prevent the finish from exposure to air and oxidizing prior to installation.

IMPORTANT NOTICE:

It is the responsibility of the customer to check for any material finish defects **BEFORE** installation. Waterstone does not warranty these finishes **AFTER** the fixture has been installed.

SUGGESTED FINISH MAINTENANCE PROCEDURE:

1. Do not allow water spots to dry on the fixture. Keep the surface clean and dry after use.
2. Periodic cleaning can be done by applying mineral oil to a clean soft cloth and gently wiping down the finish surface to clean. Make sure not to rub too hard, in that you can remove too much of the surface patina surface with aggressive cleaning.
3. Once the mineral oil has been applied, with a clean soft dry cloth gently pat the finish surface to remove any excess oil on the fixture until the fixture no longer looks "wet".
4. Never use cleaners with bleach, abrasives, or vinegar. Never use any type of abrasive pad or sponge.

ABOUT YOUR FINISH:**Polished Gold - PG
Satin Gold - SG**

This finish is done with real precious metal gold plating on the brass fixture surface. This finish has **NO PROTECTIVE COATING** and is extremely soft. Some or all of the Gold plating will be removed if any type of polish is used. Additionally, the finish will wear away with time. The gold plating is considered very delicate and can be easily scratched or scuffed. Any type of astringent cleaner or any type of abrasive cleanser, pad, cloth or sponge will damage the finish.

IMPORTANT NOTICE:

It is the responsibility of the customer to check for any material finish defects **BEFORE** installation. Waterstone does not warranty these finishes **AFTER** the fixture has been installed.

SUGGESTED FINISH MAINTENANCE PROCEDURE:

1. Do not allow water spots to dry on the fixture. Keep the surface clean and dry after use.
2. Periodic cleaning can be done with mild liquid soap only. Wipe gently with a soft cloth to clean.
3. Never use cleaners with bleach, abrasives, or vinegar. Never use any type of abrasive pad or sponge.

ABOUT YOUR FINISH:**Chrome - CH
Satin Chrome - SC**

These finishes are the most durable finishes Waterstone offers. The best general maintenance is regular cleaning. Even though these finishes are considered durable, you can never use any abrasive type cleaners, clothes, or pads to clean your fixture. Always try and keep your finishes clean and dry. Trapped moisture on the surface of your finish can lead to staining. Astringent cleaners, chlorine, bleach, along with acidic based organic cleansers are potentially harmful to these finishes. Chrome plated finishes are very tarnish resistant. However, they are not indestructible and can scratch and mar.

IMPORTANT NOTICE:

It is the responsibility of the customer to check for any material finish defects **BEFORE** installation.

SUGGESTED FINISH MAINTENANCE PROCEDURE:

1. Do not allow water spots to dry on the fixture. Keep the surface clean and dry after use.
2. Periodic cleaning can be done by applying denatured isopropyl alcohol with a soft clean cloth to gently remove surface spots.
3. Never use cleaners with bleach, abrasives, or vinegar. Never use any type of abrasive pad or sponge.



41180 Raintree Court • Murrieta, CA 92562
1-888-304-0660 • 951-304-0520
www.waterstoneco.com

★ **MADE IN AMERICA** ★

VEN-038-WHEL Rev. A