

Series 200

Pressure Balance Shower by Shower Set

1.001467

(1.001467T - Trim Only)

Alexandria Handle

16 pt.

**FEATURES:**

- Forged brass construction
- Valve cartridge 18.30.893
- Diverter cartridge: 18.30.898
- Adjustable hot limit safety stop
- Reversible cartridge
- 4.5 GPM @ 45 PSI
- Certified to meet or exceed the following codes and standards:  
ASME A112.18.1/CSAB 125.1-2012

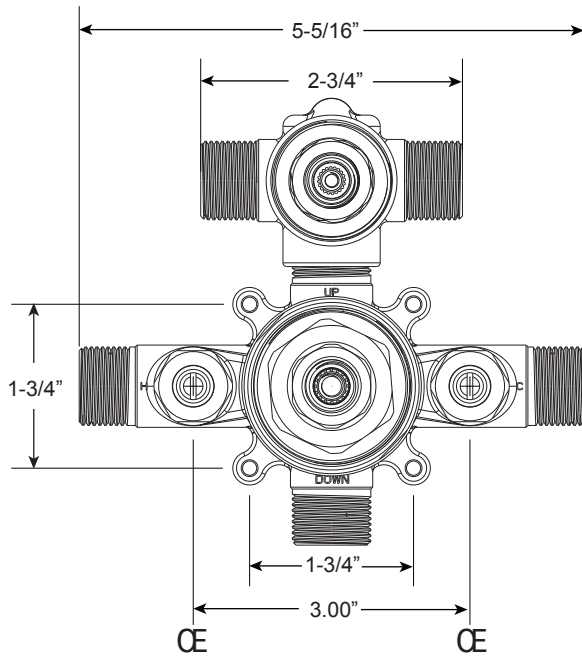

**FRONT VIEW**

**SIDE VIEW**

*\*Note: Stem and all-thread tube will be sent with handle trim.*

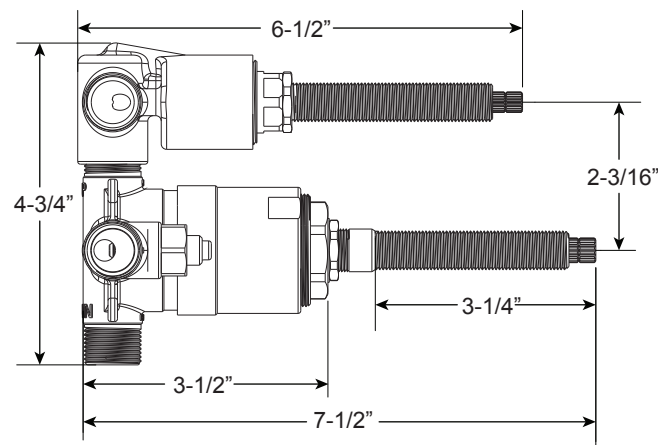

\* Current valve in use:  
Circa 4/2014 - present  
Contact Customer Service  
for Older Versions

\*\* For additional information on  
cartridges or extension kits,  
see 'Rough Valving' section  
in current catalog.

**Please Note:**

*Must purchase the two desired shower components separately. See current catalog for shower component options.*

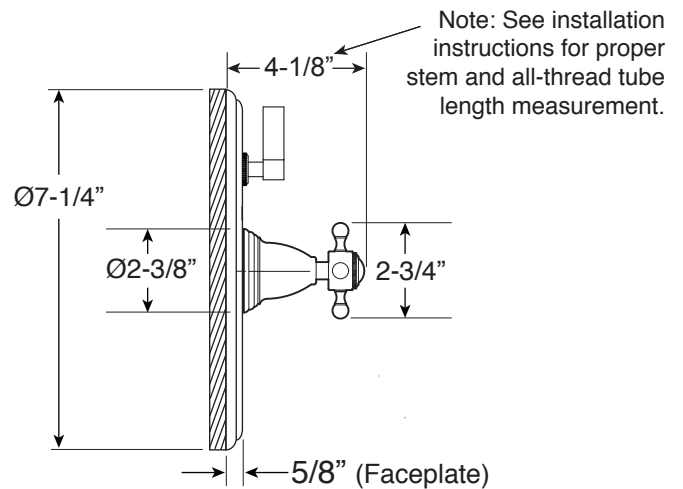

**Please Note:**

1.001467

Must purchase the two desired shower components separately.

**Alexandria Handle**

See current catalog for shower component options.

**16pt.**

<p>* Current valve in use: Circa 4/2014 - present Contact Customer Service for Older Versions</p>
<p>** For additional information on cartridges or extension kits, see 'Rough Valving' section in current catalog.</p>
<p>° 18.12.816 - Complete Diverter Trim &amp; Rough Diverter Trim will include Flipper Lever Assembly° (18.12.817) and 20 pt Stem &amp; All-Thread Kit° (18.30.897)</p>

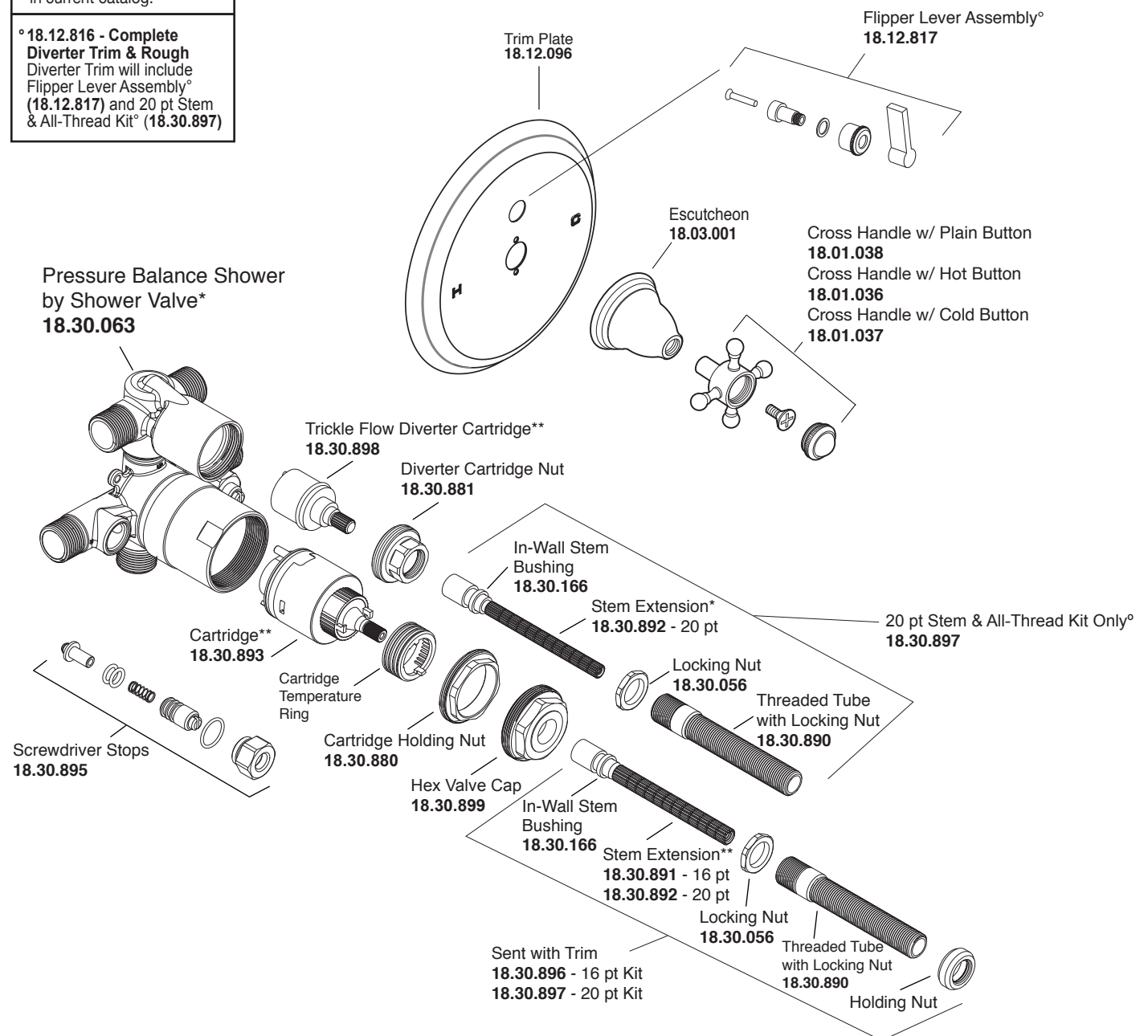

Note: Measurements are subject to cancellation. No responsibility is assumed for use of superseded or voided pages.