

Series 300

Pressure Balance Shower Set

FEATURES:

- Forged brass construction
- Valve cartridge 18.30.893
- Adjustable hot limit safety stop
- Reversible cartridge
- 5.6 GPM @ 45 PSI
- Includes showerhead, arm, and flange
- Certified to meet or exceed the following codes and standards:
ASME A112.18.1/CSAB 125.1-2012

1.001064

(1.001064T - Trim Only)

Windham Handle

16 pt.

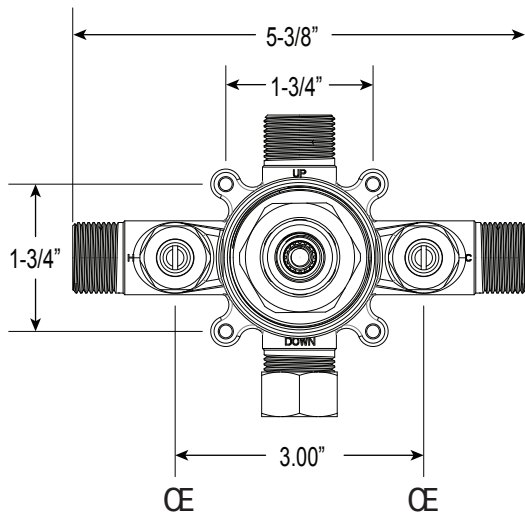

FRONT VIEW

SIDE VIEW

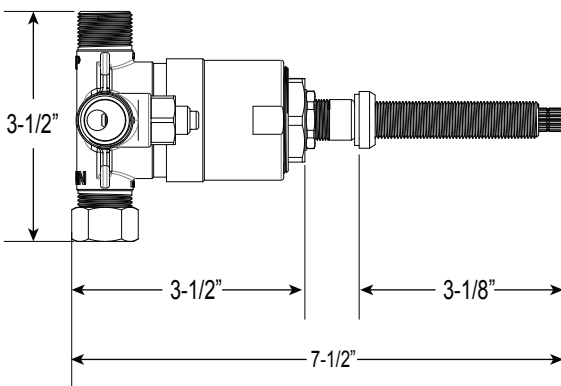

**Note: Stem and all-thread tube will be sent with handle trim.*

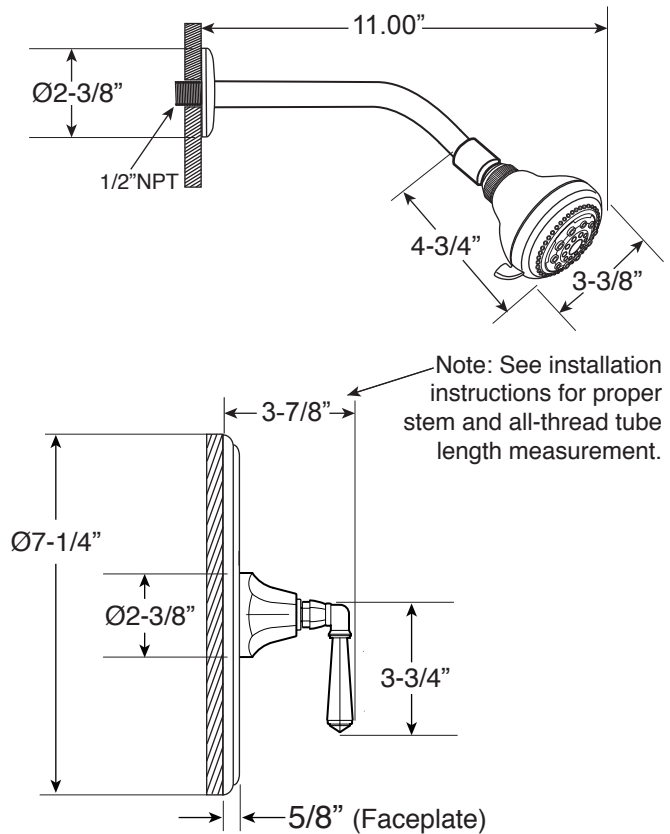

* Current valve in use:
Circa 4/2014 - present
Contact Customer Service
for Older Versions

** For additional information on
cartridges or extension kits,
see 'Rough Valving' section
in current catalog.

Note: Measurements are subject to change. No responsibility is assumed for use of superseded or voided pages.

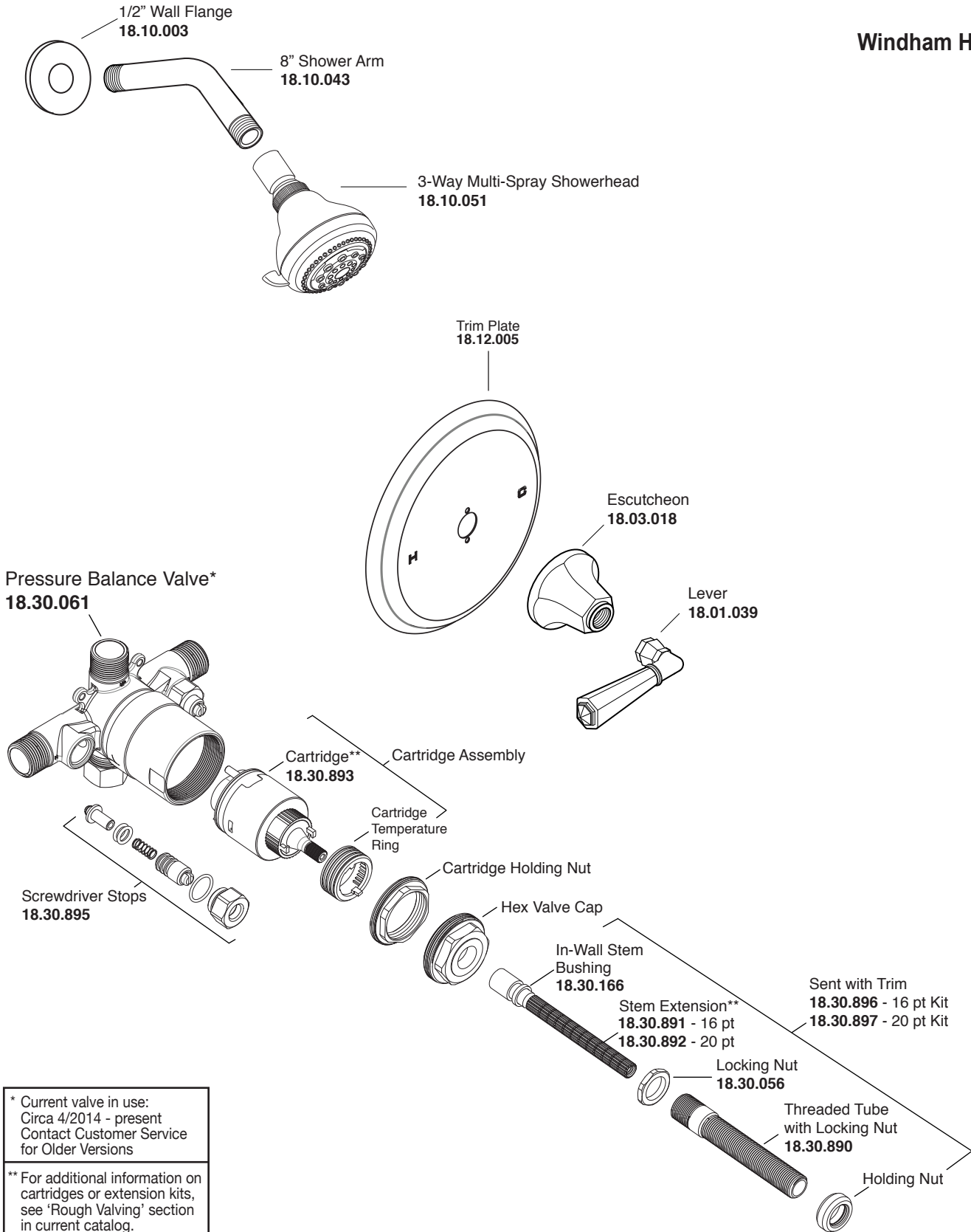

* Current valve in use:
Circa 4/2014 - present
Contact Customer Service
for Older Versions

** For additional information on
cartridges or extension kits,
see 'Rough Valving' section
in current catalog.

Note: Measurements are subject to cancellation. No responsibility is assumed for use of superseded or voided pages.