

**Series 400**

*Pressure Balance Shower Set*

**FEATURES:**

- Forged brass construction
- Valve cartridge 18.30.893
- Adjustable hot limit safety stop
- Reversible cartridge
- 5.6 GPM @ 45 PSI
- Includes showerhead, arm, and flange
- Certified to meet or exceed the following codes and standards:  
ASME A112.18.1/CSAB 125.1-2012

1.000664

(1.000664T - Trim Only)

**Portsmouth Handle**

**16 pt.**

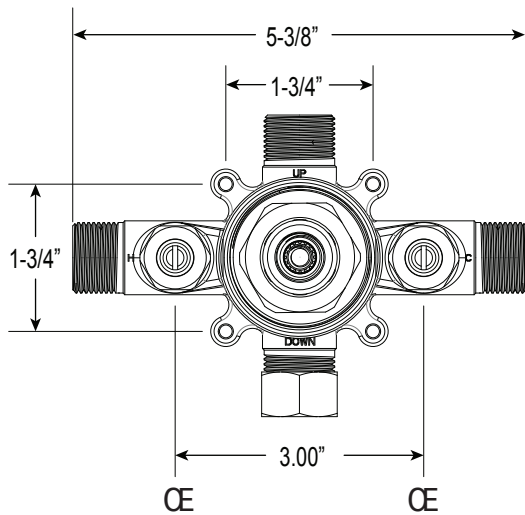

**FRONT VIEW**

*\*Note: Stem and all-thread tube will be sent with handle trim.*

**SIDE VIEW**

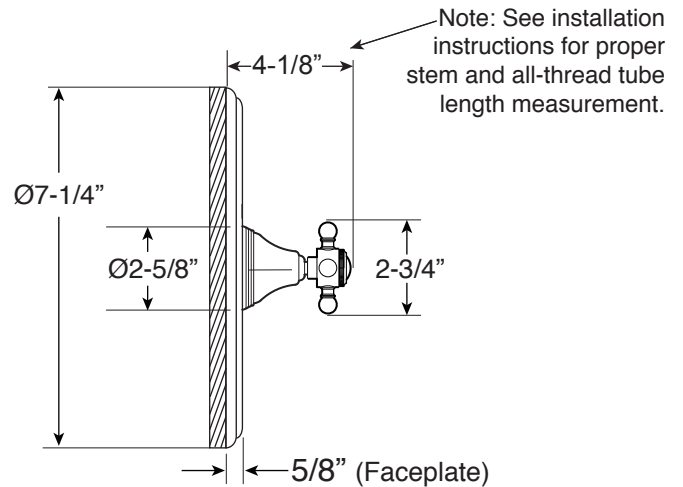
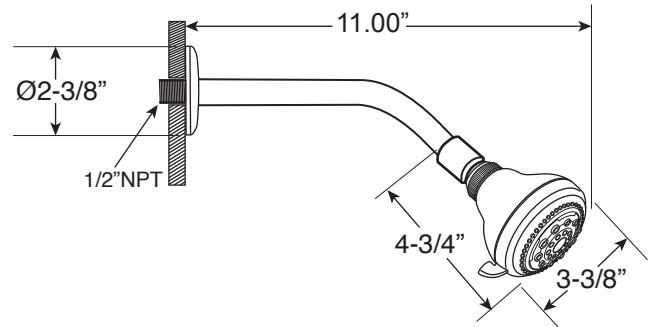
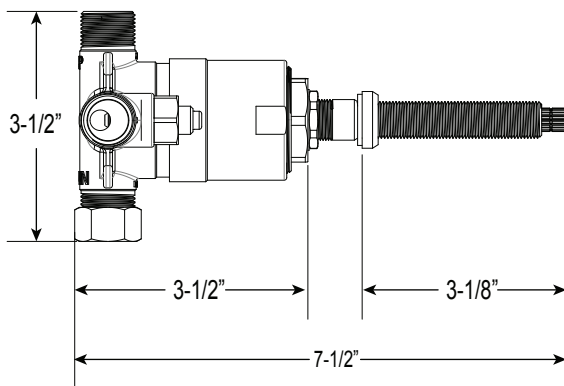

Note: See installation instructions for proper stem and all-thread tube length measurement.

\* Current valve in use:  
Circa 4/2014 - present  
Contact Customer Service  
for Older Versions

\*\* For additional information on  
cartridges or extension kits,  
see 'Rough Valving' section  
in current catalog.

Note: Measurements are subject to change. No responsibility is assumed for use of superseded or voided pages.

*Pressure Balance Shower Set*

1.000664

**Portsmouth Handle**

**16pt.**

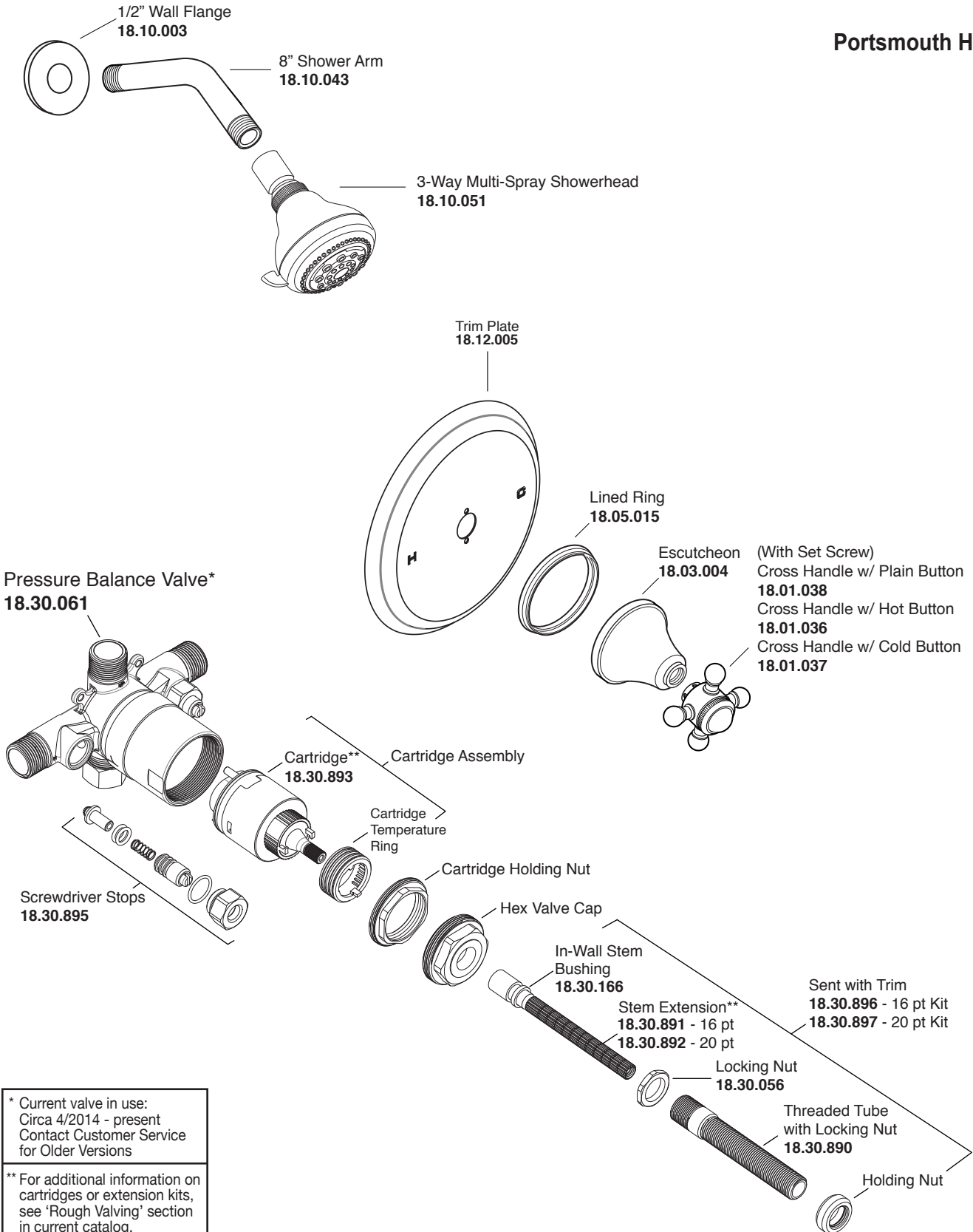

\* Current valve in use:  
Circa 4/2014 - present  
Contact Customer Service  
for Older Versions

\*\* For additional information on  
cartridges or extension kits,  
see 'Rough Valving' section  
in current catalog.

Note: Measurements are subject to cancellation. No responsibility is assumed for use of superseded or voided pages.