



ENGINEERING EXCELLENCE

## Installation Guide

### **Single Handle Tub & Shower Trim Set:**





- 4PR100TX
- 4PR300TX
- 4PR400TX

### **This product meets the following standards:**

- ASME A112.18.1
- ANSI A117.1
- CUPC / IAPMO LISTED / ADA COMPLIANT

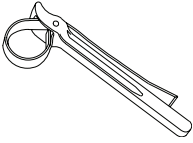
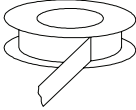
Thank you for purchasing this Pioneer quality product.

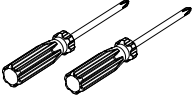
## Tools Required

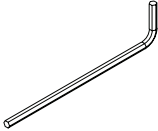
			
Strap Wrench	Teflon Tape	Thermometer	Straight & Phillips Screwdrivers
			
Plumbers Putty	Allen Wrench		

## Prior to Installation

- Observe all local plumbing and building codes before you begin installation.
- The finished wall or Tub/Shower Valve ( 4010B or 4011B) must be installed prior to installing this trim.
- Shut off main water supply.
- Pioneer reserves the right to make changes in the design of faucets without notice as specified in the pricebook.

**Caution:** (1). These products may cause personal injury due to scalding if the temperature is set too high. We recommend that temperature is set below 120 ° F (49 ° C). (2) Anti scald device or pressure balance spool is not installed in the valve. The spool is included in the trim pack. The valve won't work properly without the pressure balance spool being installed in the valve.

## Trim Installation

- Remove the temporary nipple.
- **For Slip-Fit Installation:-**
- The 1/2" nominal copper tube must be cut with length of 3-7/16" from finished wall.
- The end of copper tube should be chamfered free of burrs to prevent cutting or nicking o-ring inside the tub spout. The outside surface may be sanded free from nicks and scratches.
- Slide the spout(A) along the copper pipe. Press and twist the spout(A) over copper tube flush with the finished wall.
- Tighten the set screw, do not over-tighten.
- **For IPS Installation:-**
- The 1/2" threaded pipe nipple must be kept with the length of 1-7/16" from finished wall.
- Remove the octagonal nut inside the spout(A) by using nose plier.
- Apply Teflon Tape at the threaded connection. Screw Tub spout onto the threaded pipe nipple and tighten by strap wrench.

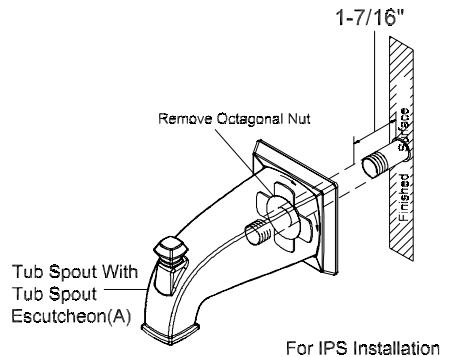
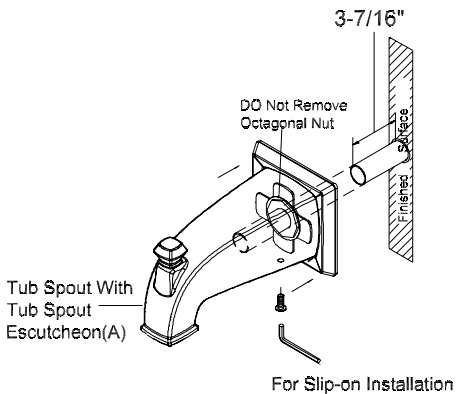

## Trim Installation

- Caution:- To avoid plugging the showerhead spray outlet use teflon tape on the shower arm threads.
- Remove temporary nipple from the shower elbow.
- Use silicon to caulk the back of the shower arm flange(B).
- Slide the shower arm flange(B) over the shower arm(C).
- Apply the teflon tape on both threaded ends of shower arm(C) and install the shower arm(C) to the shower elbow.
- Carefully tighten with a clean strap wrench.
- press the shower arm flange(B) against the finished wall.
- Flush out the system.
- Thread the showerhead(D) to the shower arm(C).

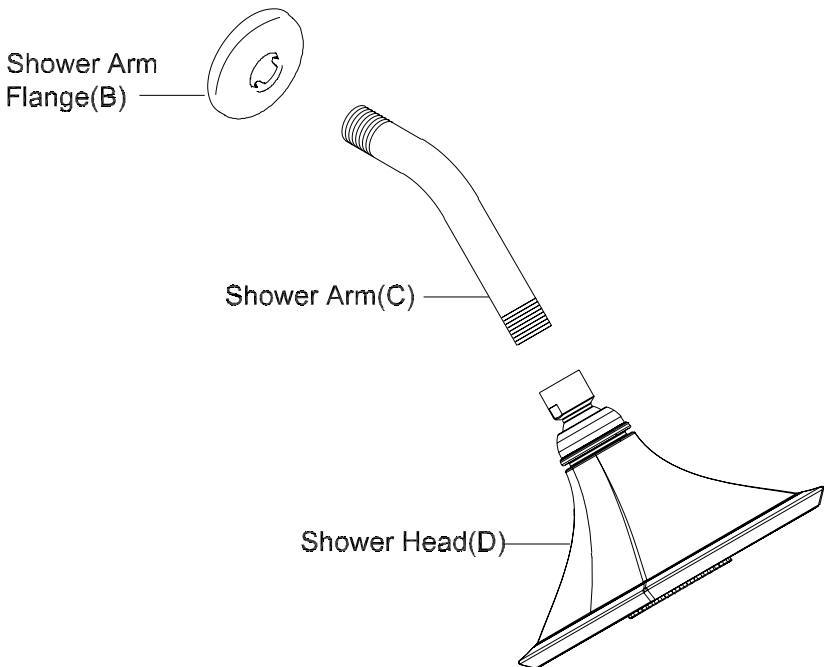

## Trim Installation

- Remove the black test plug from the valve.
- Install the pressure balance spool (E). Ensure the o-rings on the pressure balance spool does not get cut or nicked. Tighten the pressure balance spool(E) with the help of 21/32" size socket. Do not overtighten.
- Turn the stem counterclockwise to the full open position.
- Allow water to run for some time until the hot water comes out. Check the temperature with thermometer for the hot water.
- If necessary, adjust the temperature limit screw (G). Rotate the temperature limit screw (G) counterclockwise to increase the water temperature and clockwise to decrease the water temperature. Adjust to get the desired water temperature.

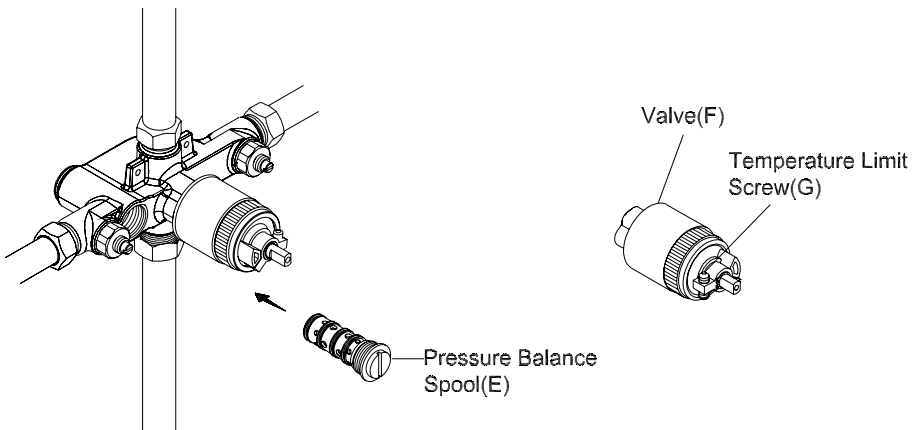

## Trim Installation

- Remove the Plastic protective dome if installed.
- Slide the face plate(H) on the valve. Ensure the rubber gasket is placed behind the face plate (H) to form water tight seal.
- Secure the face plate(H) by using silicon to caulk around the face plate (H).
- Place the handle (I) on the stem. Secure the handle by tightening the allen screw (J) with 3/32" allen wrench.

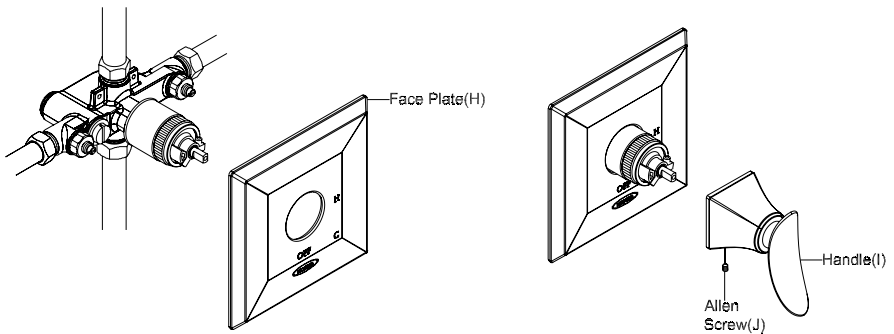

For more care information or trouble shooting inquiries about your Pioneer product, please see the contact information on the back page.





ENGINEERING EXCELLENCE

3325 S. Garfield Ave | City of Commerce, CA 90040  
Telephone: (800) 338-9468 | (323) 888-8873 | Fax: (323) 888-9515  
Hours: M - F, 7:30am to 5:00pm PST