

EAST LINEAR

Prep Sink / Bar Faucet **2008**



Features

- Solid brass construction
- Forged brass body with integral rotating spout and handles
- Euro-motion ceramic disc 35 mm valve cartridge
- ADA compliant contemporary lever handle
- Rotating spout assembly with integral supply hoses
- 7.42" (18.8 cm) spout height at outlet
- 7.13" (18.1 cm) spout reach (c-c)
- For single hole configurations
- ADA Compliant
- 1.8 GPM (6.8 LPM) Max

Codes / Standards Compliance

Meets or exceeds the following at date of manufacture:

- ASME A112.18.1/CSA B125.1
- IAPMO/cUPC
- NSF/ANSI 61, SECTION 9
- NSF/ANSI 372
- IPC
- ADA & ICC/ANSI A117.1
- Energy Policy Act of 1992
- California Energy Commission
- All applicable US Federal and State material regulations

Colors / Finishes

- 10B: Oil Rubbed Bronze
- 15: Polished Nickel
- 15S: Satin Nickel - PVD
- 26: Polished Chrome
- Other: Refer to the Newport Brass catalog for additional color/finish options.



Specified Model

Model	Description	Colors Finishes
2008	Two-Handle Prep Sink / Bar Faucet	<input type="checkbox"/> 10B <input type="checkbox"/> 15 <input type="checkbox"/> 15S <input type="checkbox"/> 26 <input type="checkbox"/> Other

Product Specification Add "Color / Finish" suffix to Model number, below.

The Single-Handle Prep Sink / Bar Faucet shall be made of solid brass construction. Faucet shall feature brass body with integral supply hoses and feature single-handle operation of a side-mounted Euro-motion ceramic disc 35 mm valve cartridge. Faucet shall have a 1.8 gallon (6.8 liter) per minute maximum flow rate. Product shall accommodate single hole configurations. Product shall incorporate a 7.42" (18.8 cm) spout height at outlet and a 7.13" (18.1 cm) spout reach (c-c). Faucet shall incorporate an ADA compliant contemporary lever handle. Prep Sink / Bar Faucet shall be Newport Brass Model 2008/____.

2008

PRODUCT DIMENSIONS *(Units are in inches)*

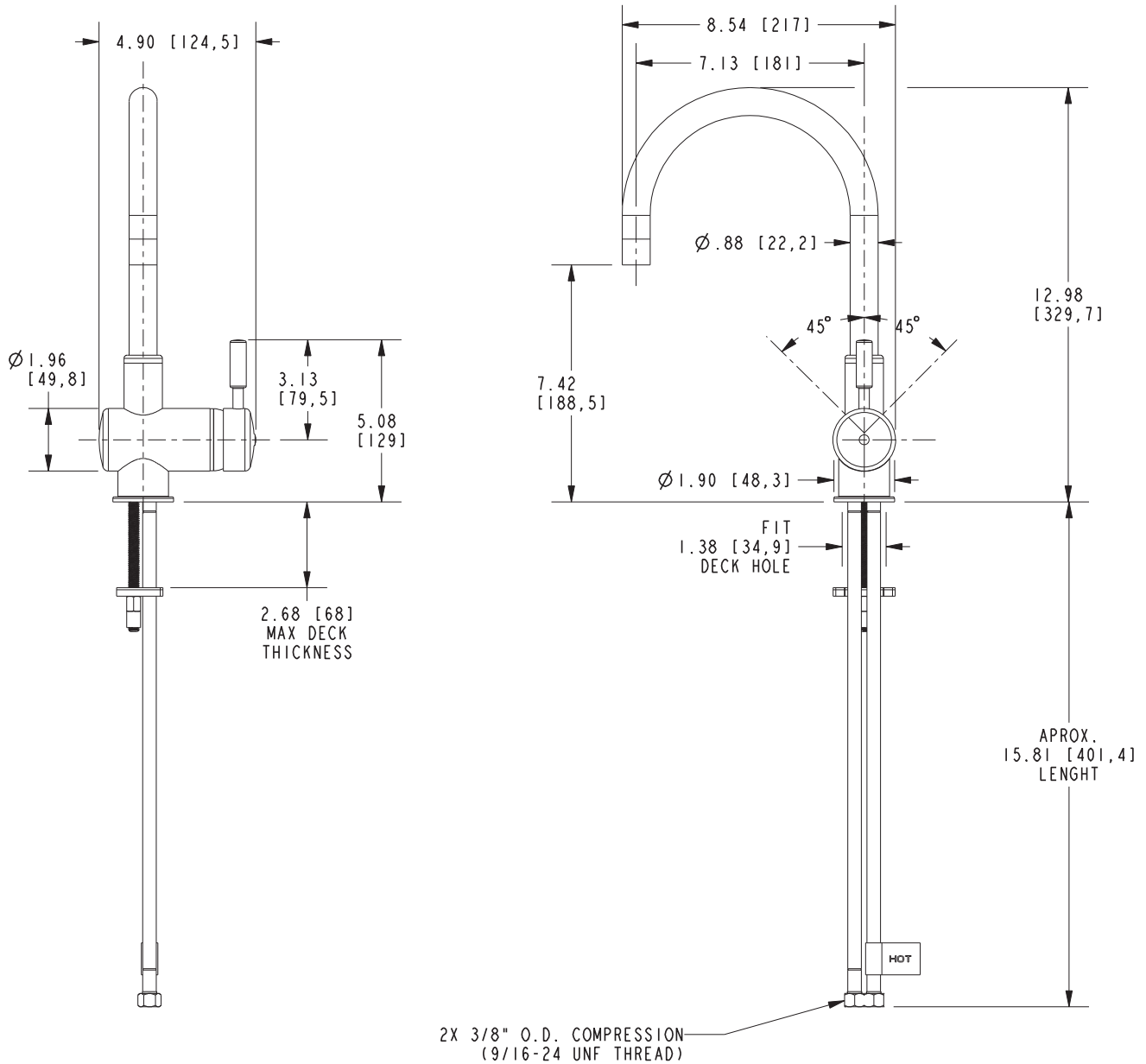

East Linear Prep Sink / Bar Faucet 2008