

SPECIFICATIONS

**MAESTRO LOTUS**

Maestro Collection

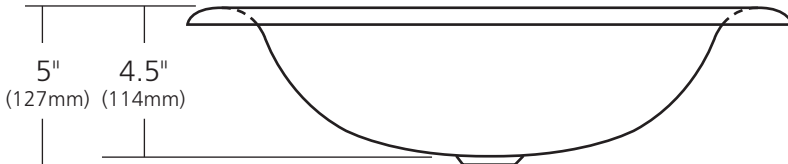
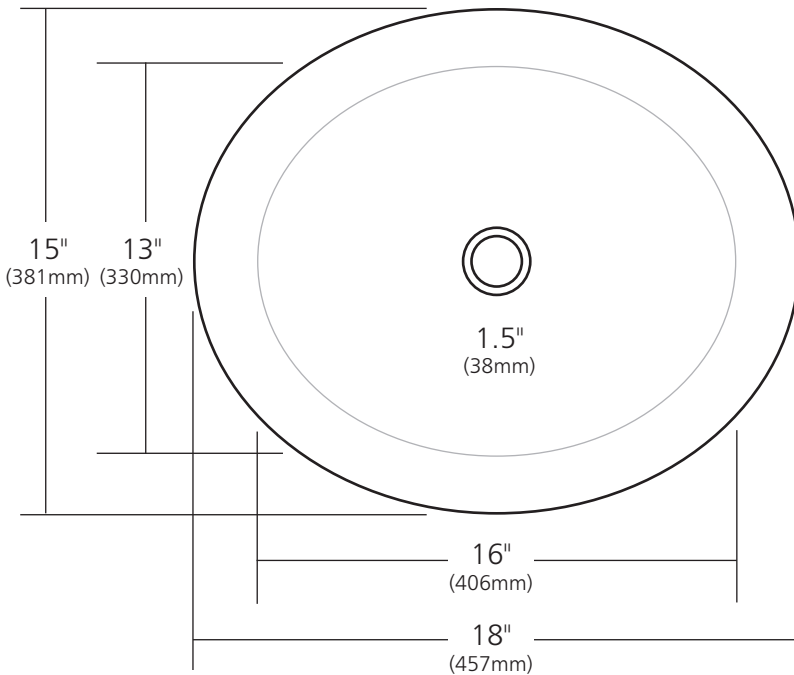

- CPS286 - Antique
- CPS386 - Tempered
- CPS586 - Brushed Nickel

**PRODUCT DETAILS**

- 18" x 15" x 5" OD (457mm x 381mm x 127mm)
- 16" x 13" x 4.5" ID (406mm x 330mm x 114mm)
- Hand hammered 15 gauge recycled copper
- 1.5" (38mm) drain opening
- Dimensions are not exact and may vary  $\pm 1/2"$  (13mm)

*This product may be customized.  
See [nativetrails.net/customization](http://nativetrails.net/customization) for details.*

**INSTALLATION**

- Drop-in

**COORDINATING PRODUCTS**

- Drains: DR120, DR150 or DR160

**STANDARDS COMPLIANCE**

- UPC/cUPC compliant
- **ADA** COMPLIANT

**IMPORTANT**

Due to the handcrafted nature of this product, it will vary in finish, texture, hammering, and other details. Dimensions may vary up to 1/2" (13mm). We strongly recommend waiting for the actual product before making any installation cuts.