

SPECIFICATIONS

AMERICANA CUBBY

Americana Collection

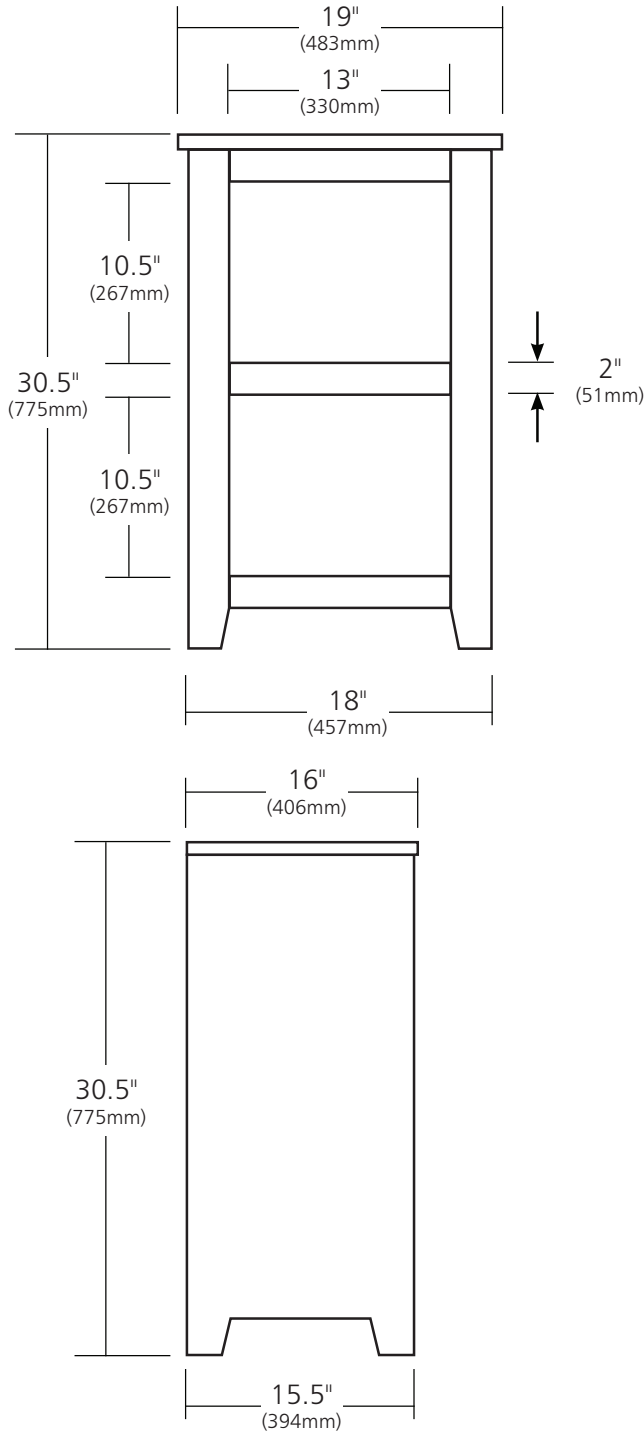

- VNB161 - Chestnut
- VNB160 - Whitewash
- VNB168 - Anvil
- VNB169 - Driftwood

PRODUCT DETAILS

- * 19"w x 16"d x 30.5"h (483mm x 406mm x 775mm)
- * Handcrafted by American artisans from reclaimed wood
- * Hand rubbed finish

INSTALLATION

- * Freestanding vanity base

COORDINATING PRODUCTS

- * Americana Mirror, Hutch, Cabinet and Vanity

IMPORTANT

Due to the handcrafted nature of this product, it will vary in finish, texture, and other details. Dimensions may vary up to 1/2" (13mm).