

SPECIFICATIONS

24" TRINIDAD VANITY

Renewal Series

VNS242- Woven Strand Bamboo

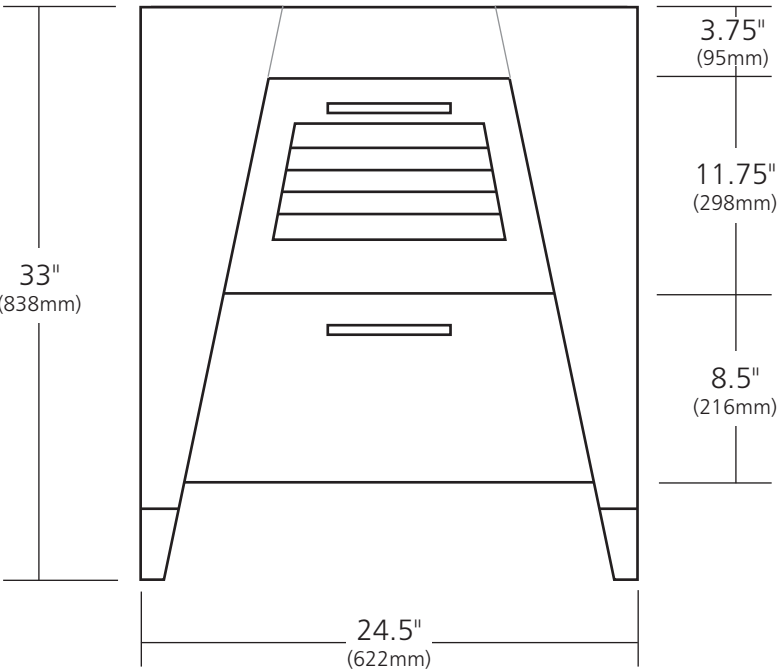

PRODUCT DETAILS

- 24.5"w x 21.75"d x 33"h (622mm x 552mm x 838mm)
- Handcrafted from solid FSC* certified Bamboo
- Two full-extension, soft-close drawers
- Top drawer includes plumbing cut-out
- Low VOC water-resistant finish

INSTALLATION

- Freestanding vanity base

COORDINATING PRODUCTS

- Any Native Trails copper or stone vanity top
- Solace Mirror (with Shelf) in Woven Strand

IMPORTANT

Due to the handcrafted nature of this product, it will vary in finish, texture, and other details. Dimensions may vary up to 1/2" (13mm).

*Forest Stewardship Council

