

The logo features the word "Kraus" in a white, serif font on a black background. The letter "K" is stylized with a faucet handle and spout integrated into its structure. A registered trademark symbol (®) is positioned to the upper right of the "s".

Kraus®

INSTALLATION MANUAL

**Crespo™ Single Lever
Bar/Prep Faucet
KPF-2700**

Thank you for purchasing Kraus

We would like to take this opportunity to thank you for your business with Kraus USA. It is our sincere hope that you are completely satisfied with your experience. We welcome any questions or comments you may have, and will be glad to assist you in the future.

For more information about Kraus products, please visit our website at:

www.kraususa.com

Please register your new Kraus product at the following web address in order to activate the warranty and receive the full benefit of customer support:

www.kraususa.com/registration

Sincerely,

Kraus Customer Service Department

Prior to Installation:

- Make sure you have all necessary parts by checking the diagram and parts list. If any part is missing or damaged, please contact Kraus Customer Service at 800-775-0703 for a replacement
- Turn off the hot and cold water supply at the angle stops and turn on the old faucet to release any built up pressure. Remove existing faucet. Clean sink or countertop to remove any debris, plumber's putty, or silicone
- Place bucket under angle stops. Turn on to flush any debris prior to installing new plumbing. Shut off angle stops
- Pre-drilled hole size requirement: 1-3/8" (min) – 1-1/2" (max)
- Max countertop thickness: 1-3/8"

Tools you will need:



Adjustable Wrench

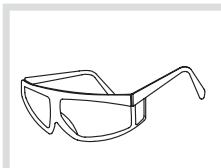

Safety Goggles

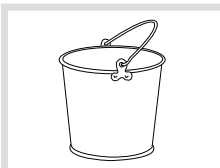

Bucket

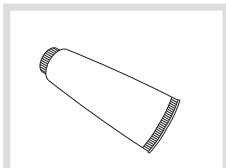

Silicone Sealant

Diagram and Parts List

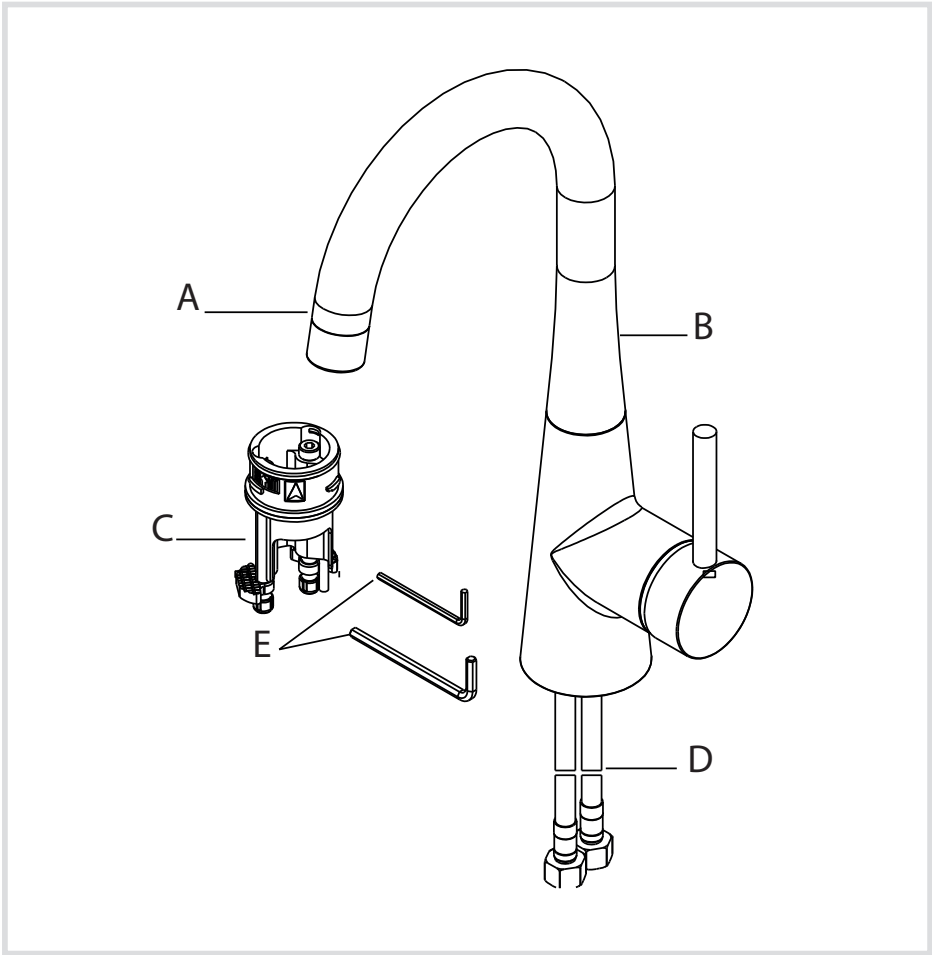

- A. Aerator
- B. Faucet Body
- C. Base
- D. Hot & Cold Waterlines
- E. Hex Wrench Set
 - E1. 2.5mm
 - E2. 4mm
- F. Base Ring

Faucet Dimensions

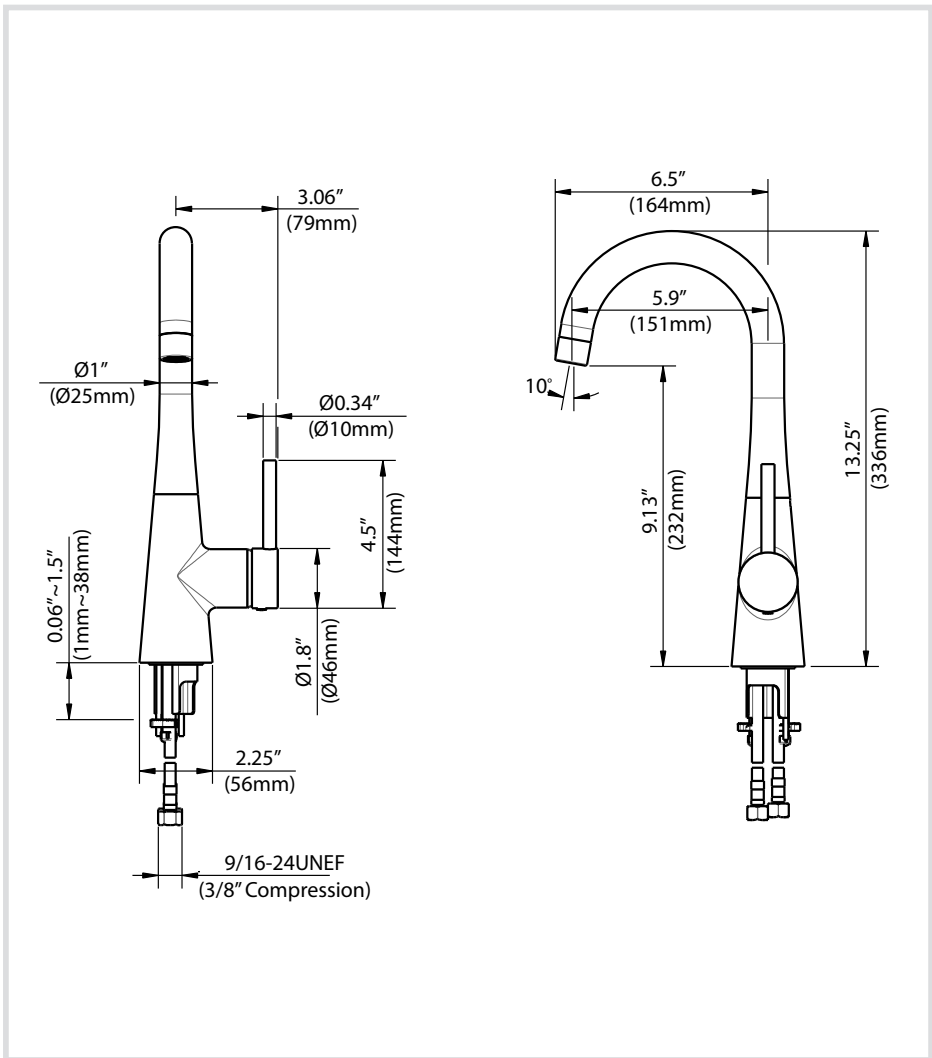

Step 1: Install base

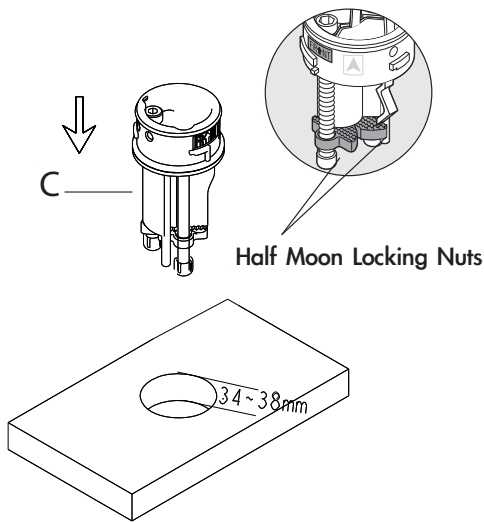

Insert base (C) into sink or countertop with “FR↑NT” facing forward. Tighten screws on base (C) with 4mm hex wrench (E) until base is secure on sink or countertop

Installer Tip: Rotate the two half-moon shaped locking nuts inward before inserting base (C) into sink or countertop

Step 2: Install & secure faucet

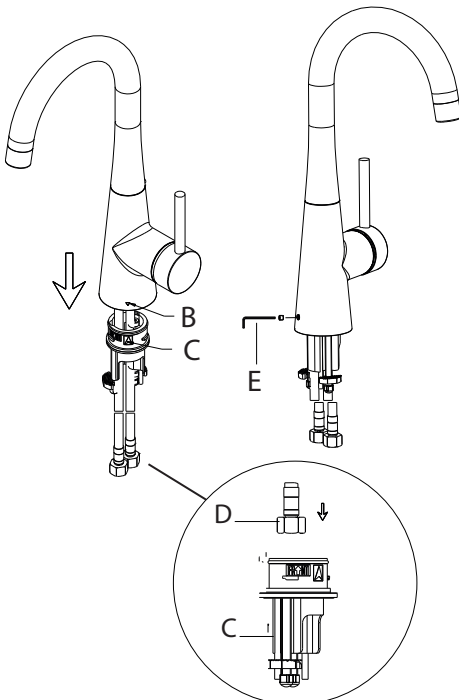

Insert hot & cold waterlines (D), one by one, in large hole of base (C). Align arrow on faucet body (B) with arrow on base (C). Attach faucet body (B) to base (C) and turn counter-clockwise. Secure faucet body (B) by tightening the set screw with 2.5mm hex wrench (E)

Installer Tip: Please loosen set screw from faucet body (B) prior to securing to base (C)

Step 3: Connect waterlines to main valve

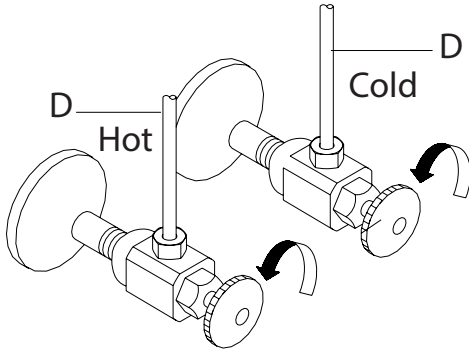

Thread hot & cold waterlines (D) onto angle stops. Tighten with adjustable wrench until snug. Turn on the angle stops and check for leaks (DO NOT TURN FAUCET ON)

Step 4: Flush faucet

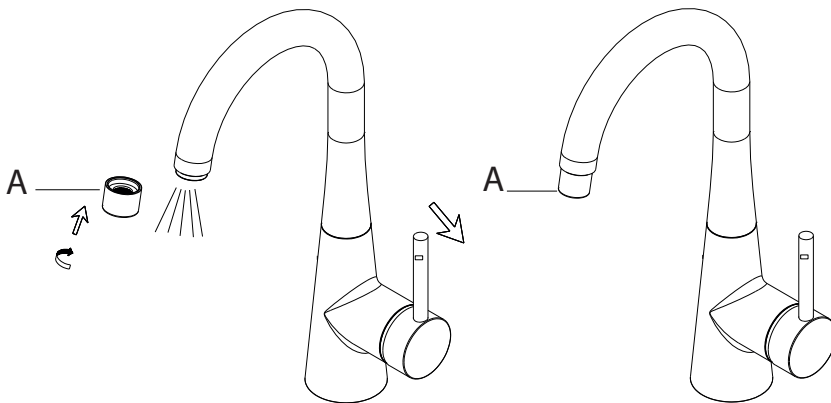

Remove aerator (A). Turn faucet on for 1 minute to flush any debris. Reconnect aerator (A)

Replacement Part List

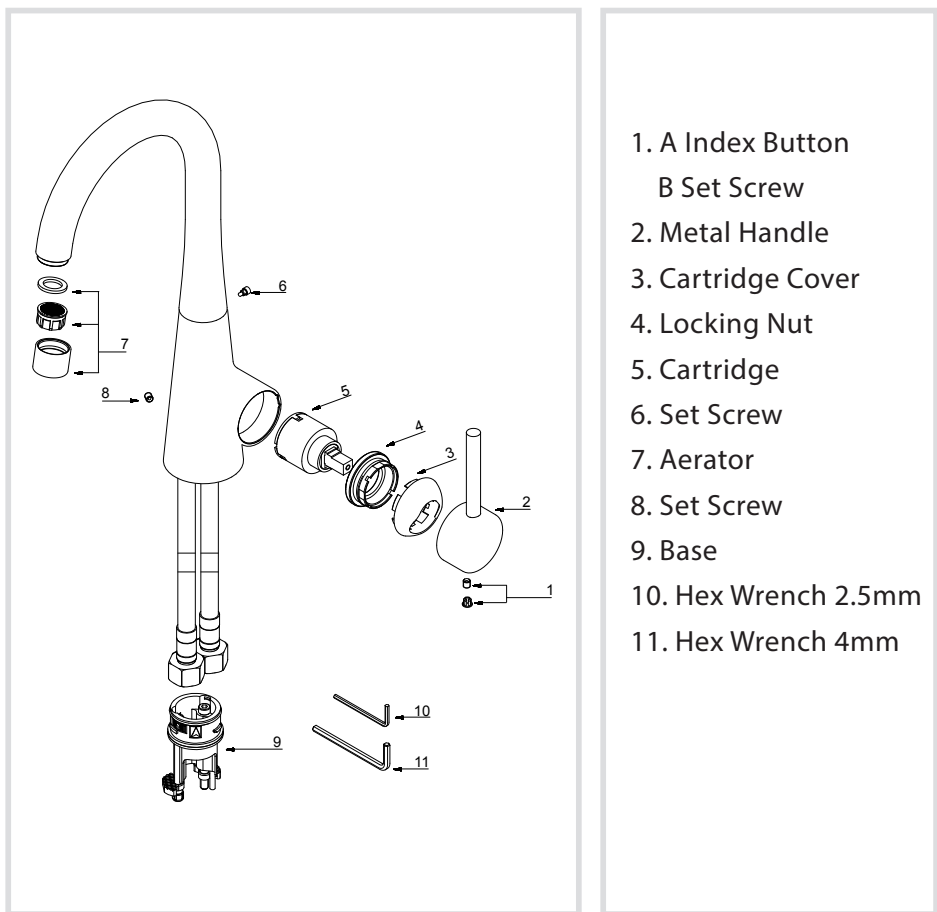

Trouble - Shooting

If you have followed the instructions carefully and your faucet still does not work properly, take the following corrective steps:

PROBLEM	CAUSE	ACTION
Water will not shut off completely	Cartridge (5) may need to be adjusted or replaced	Remove index button (1A). Loosen set screw (1B) with 2.5mm hex wrench (12). Remove metal handle (2). Remove cartridge cover (3) by hand only. Remove locking nut (4) with an adjustable wrench. Remove ceramic disc cartridge (5). Check for cracks
Dripping from aerator	Washer may be missing or not seated correctly	Remove aerator (7). Make sure washer is present and seated correctly

Care & Maintenance

*To keep the product clean & shining, follow the steps below:

1. Rinse with clean water & dry with a soft cloth
2. Do not clean with soaps, acid, polish, abrasives, or harsh cleaners
3. Do not use cloth with a coarse surface
4. Unscrew the aerator and clean when necessary

*This installation manual is subject to change without further notice.

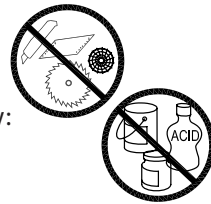

Codes/Standards Applicable:



KRAUS LIMITED LIFETIME WARRANTY

This product has been manufactured and tested to the highest quality standards by Kraus USA Inc. ("Kraus"). We offer our customers thoughtfully crafted fixtures & accessories, engineered for enduring performance over years of use.

WHO IS COVERED BY THE WARRANTY

This warranty extends to the original purchaser only. This warranty is not transferable, between homes or owners and is only applicable to residential use.

WHAT IS COVERED BY THE WARRANTY

Kraus warrants this product against defects due to material or craftsmanship error during the warranty period: Kraus will provide replacement parts at no charge, or at its option, replace any product or part of the product that is deemed defective, under normal installation, use, service and maintenance. If Kraus is unable to provide a replacement and repair is not practical or cannot be made in timely fashion, Kraus may elect to refund the purchase price in exchange for the return of the product.

CONDITIONS AND EXCLUSIONS

Like other home fixtures, Kraus products will require light maintenance to ensure proper function. We provide you with complete knowledge to perform this maintenance and can also recommend resources if you are unable to fulfill this service.

- A. Kraus will not be responsible for product failures due to lack of maintenance or proper use. Please read your care and maintenance documentation to determine the limits of proper use.
- B. The original sales receipt, order number, and/or proof of purchase must be presented at the time of the warranty claim, without exception, for this warranty to be applied to all Kraus products.
- C. Kraus recommends installing all Kraus products with a licensed, professional plumber. Kraus will not be held responsible for any damage or product failure due to improper installation, misuse, or failure to use a licensed professional. Please read your care and maintenance documentation to determine the limits of proper use.
- D. Commercial use will automatically void this warranty.
- E. This warranty is not applicable to Kraus products purchased from an unauthorized seller. For a complete list of authorized sellers please visit <http://www.kraususa.com/where-to-buy.html>

NON-APPLICABILITY OF THIS WARRANTY

By the purchase and use of our products, you agree that Kraus is not liable for incidental, consequential or special damages associated with the return, replacement, installation or use of your product. This includes freight costs, cartridge replacement, labor, travel time, lost profit, home damages and other contingent liabilities and costs (including, without limitation, costs associated with experts, investigations, analyses, attorneys and other professionals and services). The Kraus warranty is a comprehensive and explicit limit of liability, and all items outside of it are not addressable by or the responsibility of Kraus. Certain states have variances regarding implied warranties and in those situations we remain fully compliant.

KRAUS USA Inc. makes no implication that products comply with any or all local building or plumbing codes. It is the consumer's responsibility to determine local code compliance. This warranty extends to the original purchaser and first consumer.

HELP LINE

Our customer service hours are Monday – Friday, 9am – 8pm EST.
Be sure to visit our website at www.kraususa.com

If you are a homeowner please contact a Kraus Customer Service Representative at:

Kraus USA, Inc.
12 Harbor Park Drive
Port Washington, NY 11050
Toll-free 800-775-0703
Customerservice@kraususa.com

If you are a plumbing contractor or trade professional please contact a Kraus Pro Representative at:

Kraus USA, Inc.
12 Harbor Park Drive
Port Washington, NY 11050
516-801-8955
Proservice@kraususa.com

If you are an Authorized Partner please contact a Partner Support Representative at:

Kraus USA, Inc.
12 Harbor Park Drive
Port Washington, NY 11050
516-801-8954
Partnersupport@kraususa.com

In requesting warranty service, please be ready to provide:

1. Proof of purchase.
2. A description of the problem.

Kräus®

www.kraususa.com