

Kräus[®]

INSTALLATION MANUAL

Coda Single Lever Vessel Faucet

FVS-13800

Thank you for purchasing Kraus

We would like to take this opportunity to thank you for your business with Kraus USA. It is our sincere hope that you are completely satisfied with your experience. We welcome any questions or comments you may have, and will be glad to assist you in the future.

For more information about Kraus products, please visit our website at:

www.kraususa.com

Please register your new Kraus product at the following web address in order to activate the warranty and receive the full benefit of customer support:

www.kraususa.com/registration

Sincerely,

Kraus Customer Service Department

Prior to Installation:

- Make sure you have all necessary parts by checking the diagram and parts list. If any part is missing or damaged, please contact Kraus Customer Service at 800-775-0703 for a replacement
- Turn off the hot and cold water supply at the angle stops and turn on the old faucet to release any built up pressure. Remove existing faucet. Clean sink or countertop to remove any debris, plumber's putty, or silicone
- Place bucket under angle stops. Turn on to flush any debris prior to installing new plumbing. Shut off angle stops
- Pre-drilled hole size requirement: 1-3/8" (min) – 1-1/2" (max)
- Max countertop thickness: 1-3/8"

Tools you will need:

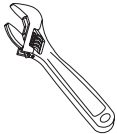

Adjustable Wrench

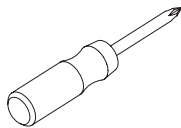

Phillips Screwdriver



Safety Goggles



Bucket

FVS-13800 Diagram and Parts List

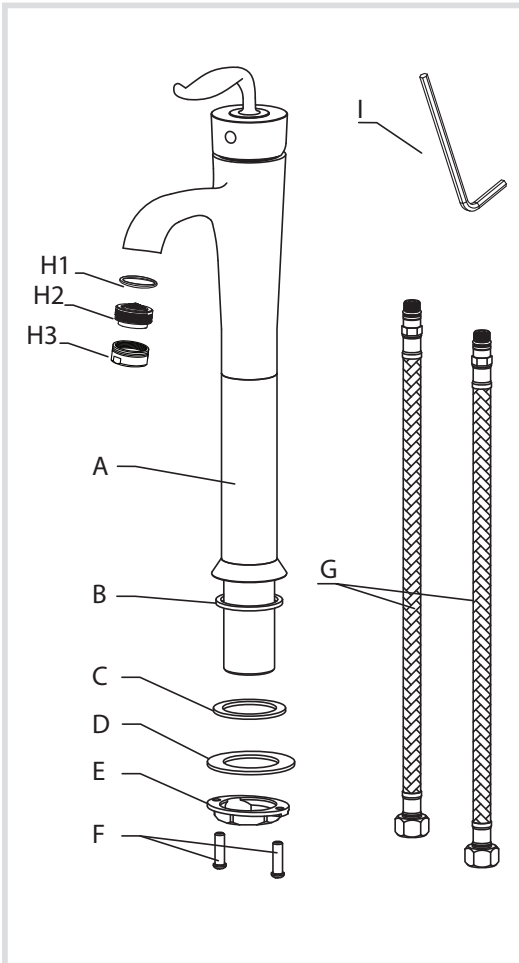

- A. Faucet Body
- B. Base O-Ring
- C. Rubber Washer
- D. Metal Washer
- E. Mounting Nut
- F. Mounting Screws
- G. Hot & Cold Waterlines
- H. Aerator Assembly
 - H1. Aerator Washer
 - H2. Aerator
 - H3. Aerator Cover
- I. Hex Wrench

Faucet Dimensions

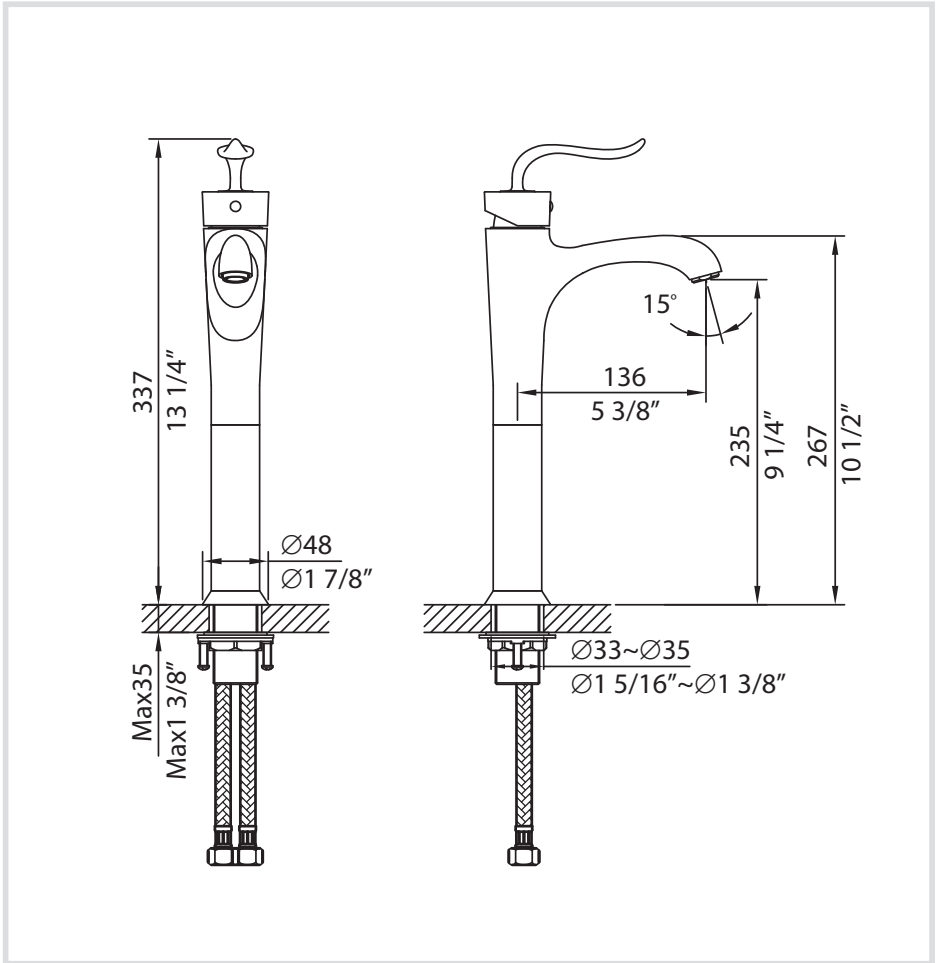

Step 1: Install mounting hardware and waterlines

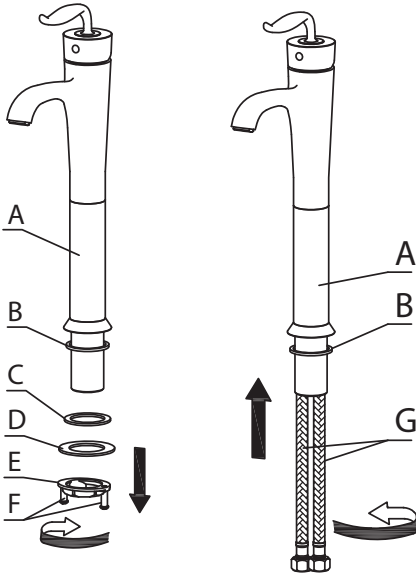

Remove mounting nut (E) with mounting screws (F) attached. Remove metal washer (D), and rubber washer (C) from threaded mounting pipe. Place faucet body (A) on a soft cloth, spout facing up. Secure the hot & cold waterlines (G) at the base of the faucet (HAND-TIGHTEN ONLY)

- A. Hot Side: Left
- B. Cold Side: Right

Step 2: Install faucet

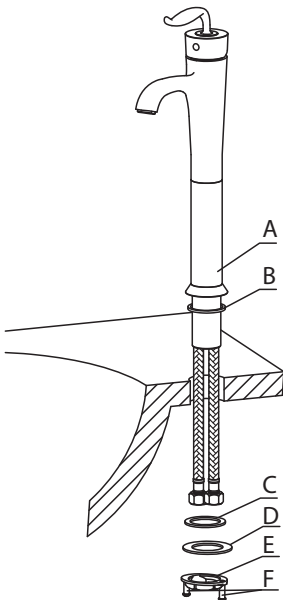

Install faucet body (A) through 1-3/8" hole in countertop, with hot & cold waterlines (G) and base O-ring (B) attached. Attach rubber washer (C), metal washer (D), and mounting nut (E) to threaded mounting pipe

Step 3: Secure faucet

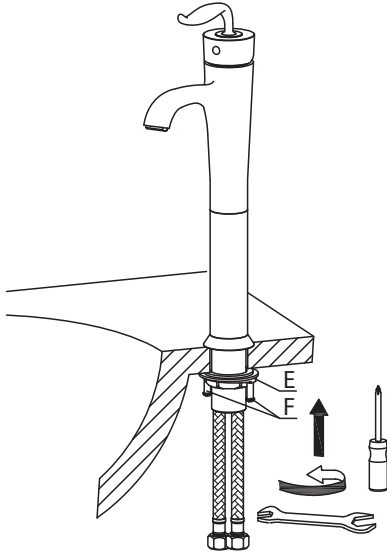

After adjusting direction of faucet body (A), tighten mounting nut (E) with adjustable wrench until snug. Secure mounting nut (E) by tightening mounting screws (F) with a Phillips head screwdriver

Step 4: Connect waterlines to faucet and main valve

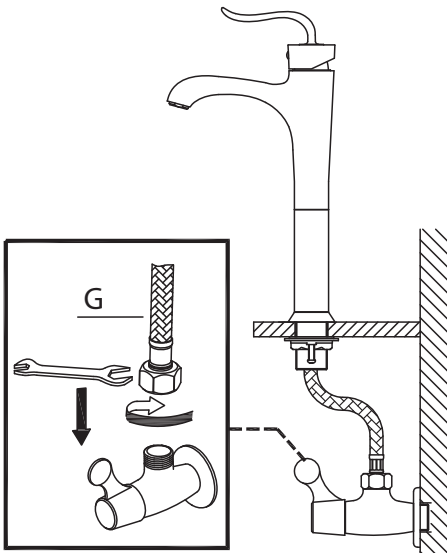

Thread hot & cold waterlines (G) onto angle stops and tighten with adjustable wrench until snug. Turn on angle stops and check for leaks

Step 5: Flush faucet

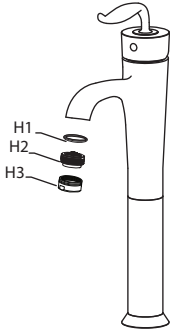

Remove aerator assembly (H). Loosen aerator cover (H3) with adjustable wrench. Remove aerator (H2) and aerator washer (H1). Turn water on for 1 minute to remove any debris. Reassemble aerator assembly (H)

Replacement Part List - FVS-13800

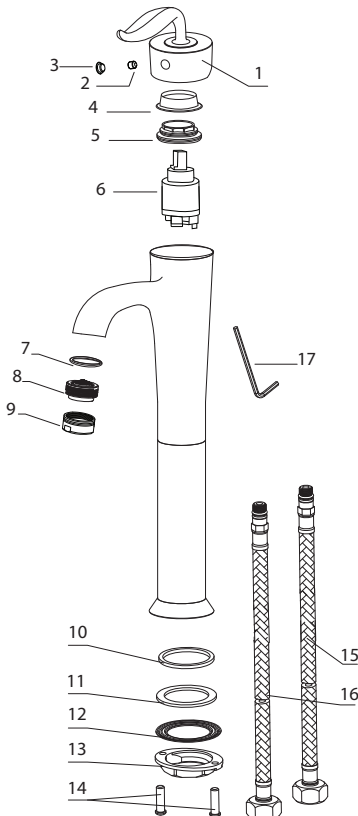

1. Metal Handle
2. Set Screw
3. Cover Button
4. Cartridge Cover
5. Locking Nut
6. Cartridge
7. Aerator Washer
8. Aerator
9. Aerator Cover
10. Base O-Ring
11. Rubber Washer
12. Metal Washer
13. Mounting Nut
14. Mounting Screw
15. Cold Waterline
16. Hot Waterline
17. Hex Wrench

Trouble - Shooting

If you have followed the instructions carefully and your faucet still does not work properly, take the following corrective steps:

PROBLEM	CAUSE	ACTION
Leakage under the handle	Locking nut (5) has come loose	Remove cover button (3). Loosen set screw (2) with hex wrench (17). Remove metal handle (1). Unscrew cartridge cover (4) (by hand only). Tighten locking nut (5) with adjustable wrench
Aerator drips or has inconsistent water flow pattern	Aerator (8) may be dirty or not seated properly	Unscrew aerator cover (9) with adjustable wrench. Remove aerator (8) and clean out debris
Water will not shut off completely	Cartridge (6) may need to be adjusted or replaced	Remove cover button (3). Loosen set screw (2) with hex wrench (17). Remove metal handle (1). Unscrew cartridge cover (4) (by hand only). Unscrew locking nut (5) with adjustable wrench. Remove ceramic disc cartridge (6). Check for cracks

Care & Maintenance

*To keep the product clean & shining, follow the steps below:



1. Rinse with clean water & dry with a soft cloth
2. Do not clean with soaps, acid, polish, abrasives, or harsh cleaners
3. Do not use cloth with a coarse surface
4. Unscrew the aerator and clean when necessary

*This installation manual is subject to change without further notice.

Codes/Standards Applicable:



NSF/ANSI 61



ASME A112.18.1M
1.5GPM 5.7L/min maximum

KRAUS LIMITED LIFETIME WARRANTY

This product has been manufactured and tested to the highest quality standards by Kraus USA Inc. ("Kraus"). We offer our customers thoughtfully crafted fixtures & accessories, engineered for enduring performance over years of use.

WHO IS COVERED BY THE WARRANTY

This warranty extends to the original purchaser only. This warranty is not transferable, between homes or owners and is only applicable to residential use.

WHAT IS COVERED BY THE WARRANTY

Kraus warranties this product against defects due to material or craftsmanship error during the warranty period: Kraus will provide replacement parts at no charge, or at its option, replace any product or part of the product that is deemed defective, under normal installation, use, service and maintenance. If Kraus is unable to provide a replacement and repair is not practical or cannot be made in timely fashion, Kraus may elect to refund the purchase price in exchange for the return of the product.

CONDITIONS AND EXCLUSIONS

Like other home fixtures, Kraus products will require light maintenance to ensure proper function. We provide you with complete knowledge to perform this maintenance and can also recommend resources if you are unable to fulfill this service.

- A.** Kraus will not be responsible for product failures due to lack of maintenance or proper use. Please read your care and maintenance documentation to determine the limits of proper use.
- B.** The original sales receipt, order number, and/or proof of purchase must be presented at the time of the warranty claim, without exception, for this warranty to be applied to all Kraus products.

C. Kraus recommends installing all Kraus products with a licensed, professional plumber. Kraus will not be held responsible for any damage or product failure due to improper installation, misuse, or failure to use a licensed professional. Please read your care and maintenance documentation to determine the limits of proper use.

D. Commercial use will automatically void this warranty.

E. This warranty is not applicable to Kraus products purchased from an unauthorized seller. For a complete list of authorized sellers please visit <http://www.kraususa.com/where-to-buy.html>

NON-APPLICABILITY OF THIS WARRANTY

By the purchase and use of our products, you agree that Kraus is not liable for incidental, consequential or special damages associated with the return, replacement, installation or use of your product. This includes freight costs, cartridge replacement, labor, travel time, lost profit, home damages and other contingent liabilities and costs (including, without limitation, costs associated with experts, investigations, analyses, attorneys and other professionals and services). The Kraus warranty is a comprehensive and explicit limit of liability, and all items outside of it are not addressable by or the responsibility of Kraus. Certain states have variances regarding implied warranties and in those situations we remain fully compliant.

KRAUS USA Inc. makes no implication that products comply with any or all local building or plumbing codes. It is the consumer's responsibility to determine local code compliance. This warranty extends to the original purchaser and first consumer.

HELP LINE

For additional assistance at any point in the installation process, please call us at 1.800.775.0703 or email us at info@kraususa.com

Our customer service hours are Monday – Friday, 9am – 8pm EST.
Be sure to visit our website at www.kraususa.com

Kräus®

www.kraususa.com