

AXENT
SWITZERLAND

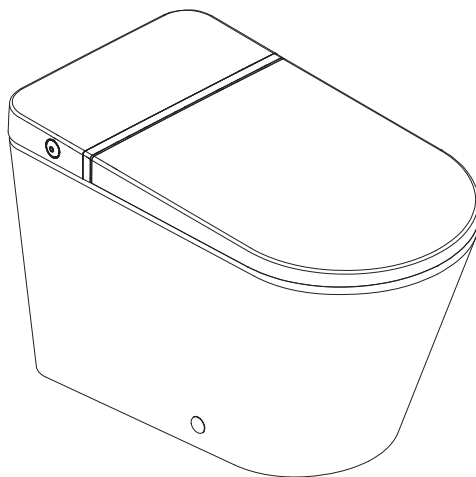

PRIMUS

USER MANUAL



SAFETY SYMBOLS

The following warning signs warn you of dangerous situations and their severity:



DANGER!

High Risk, Lethal Hazards, Severe Injuries



WARNING!

Medium Risk, Severe Injuries



CAUTION!

Low Risk, Minor Injuries



NOTE!

Damage to Property

NORMAL USAGE

This product is meant for indoors usage only.

AXENT undertakes no liability for abnormal usage.

SAFETY INSTRUCTIONS

READ ALL INSTRUCTIONS BEFORE USING

SAVE THESE INSTRUCTIONS

Information for the user

Children or persons with limited physical/mental capabilities may require supervision or proper instructions/guidance prior to or during use. Ensure that children cannot play with intelligent toilet.

Repairs must only be carried out by a person with the necessary expertise

Do not carry out modifications, tamper with, install additional equipment, or attempt to repair the intelligent toilet. Improperly performed repairs can lead to accidents, injuries, or damage to the product.

Avoid malfunctions and damage to the product as a result of improper use

If toilet is moved from a cold location to a warm location, condensation may form. Leave the unit switched off for a few hours.

Do not install the toilet in rooms where the temperature will be less than 4 °C (39 °F).

Do not place open flames, candles, cigarettes, or similar objects on or by the toilet.

Do not reuse old hoses or water lines. Please use new water lines when installing.

Do not install the toilet next to items that would potentially expose the toilet to a large amount of water.

Do not climb on or stand on the product.

Do not place any heavy objects on the lid.

Do not open or close the lid or seat with force.

Do not drop or insert any object into any openings or hoses.

TECHNICAL SUPPORT

For any questions or any assistance with this product, please contact your dealer or call us at

1-800-769-4857

support@axentproducts.com

www.axentbath.us

SCOPE OF DELIVERY

Standard delivery contents

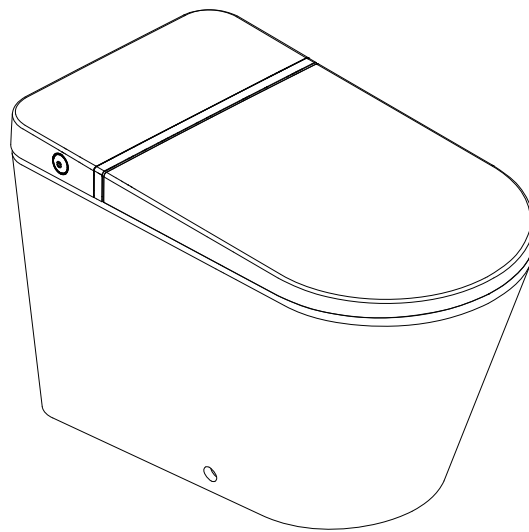

Main Body

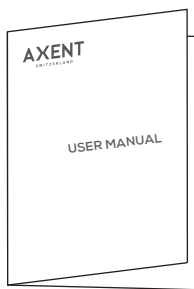

User Manual

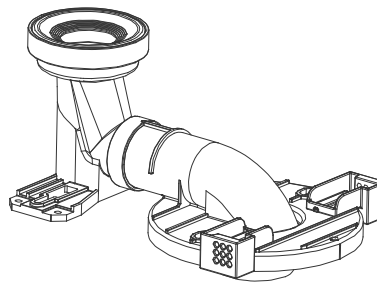

12" Flange

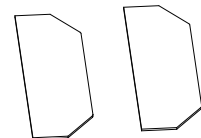

Adhesive

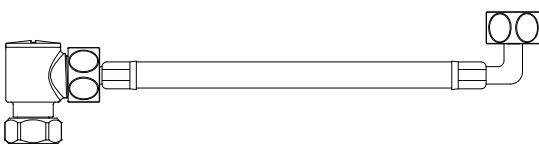

Inlet Hose and Filter
(Filter Adapter Requires 1/2" Pipe Thread Connection.)



Bowl Plug/ Magnet Tool



Bowl Mounting Hardware



The below parts are not included with the toilet. Please prepare before installation.

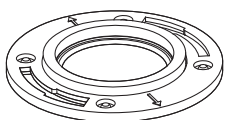

Floor Mount



Bolts



Wax Ring

1

1

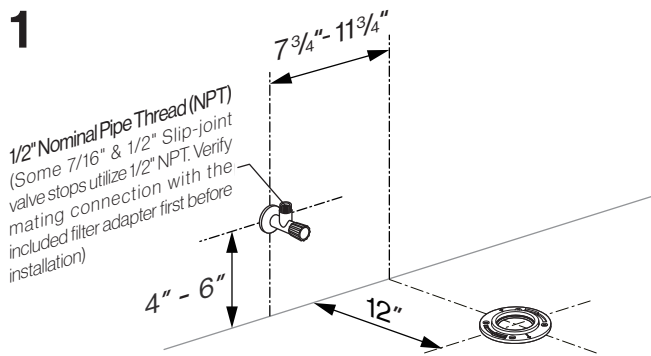

! Please verify these dimensions before beginning installation. These dimensions may vary in some locations.

2

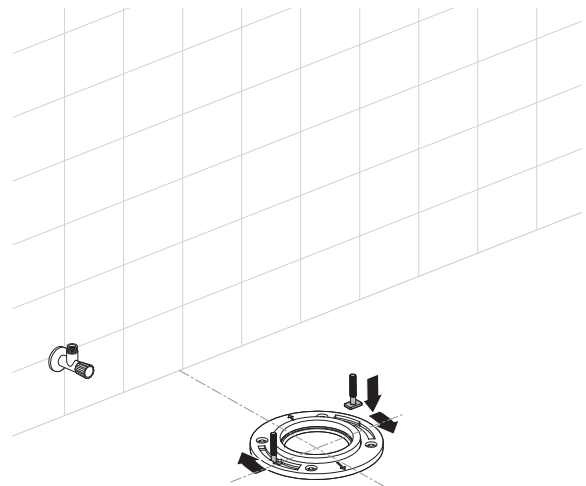

3

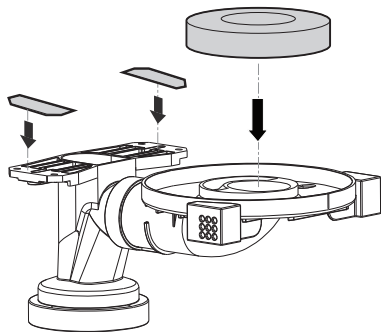

4

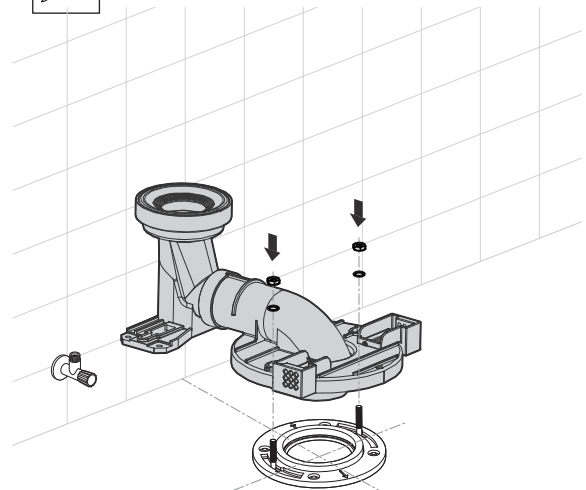

5

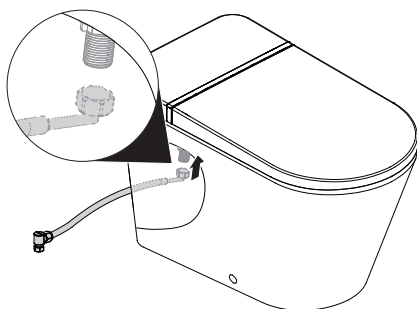

6

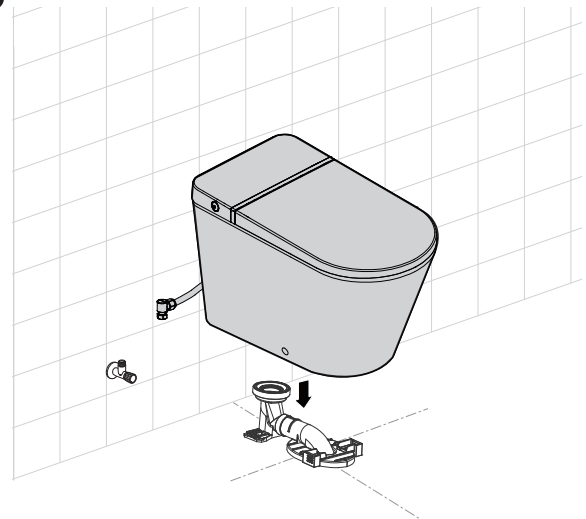

PRIMUS

7 

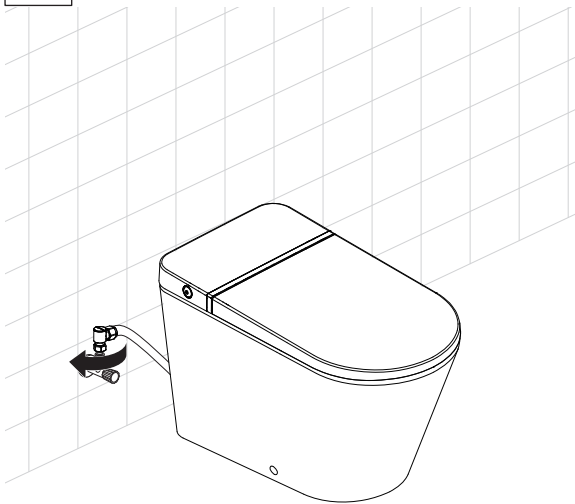

8 

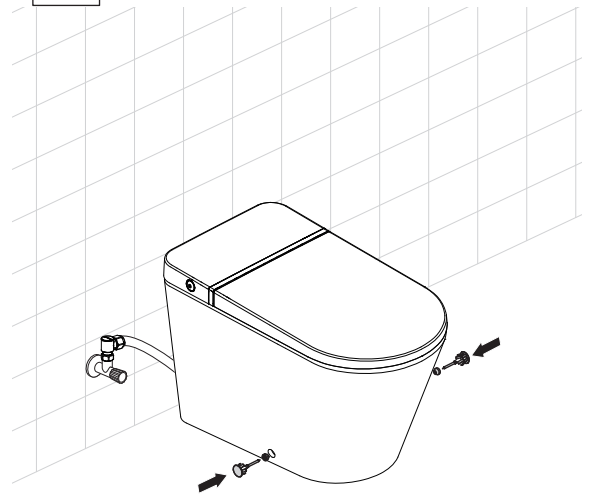

9

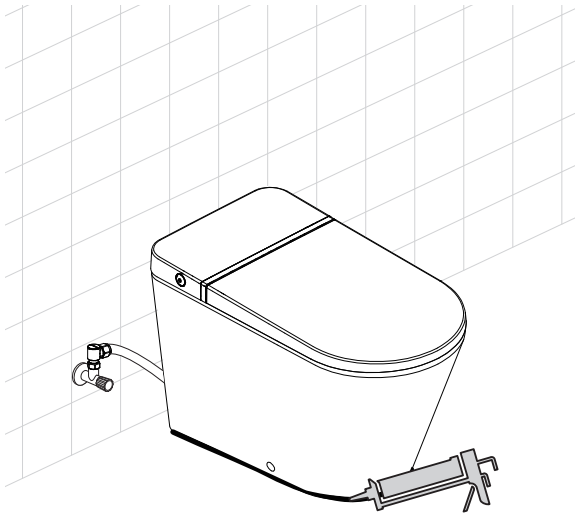

2

Test bidet function after installation.

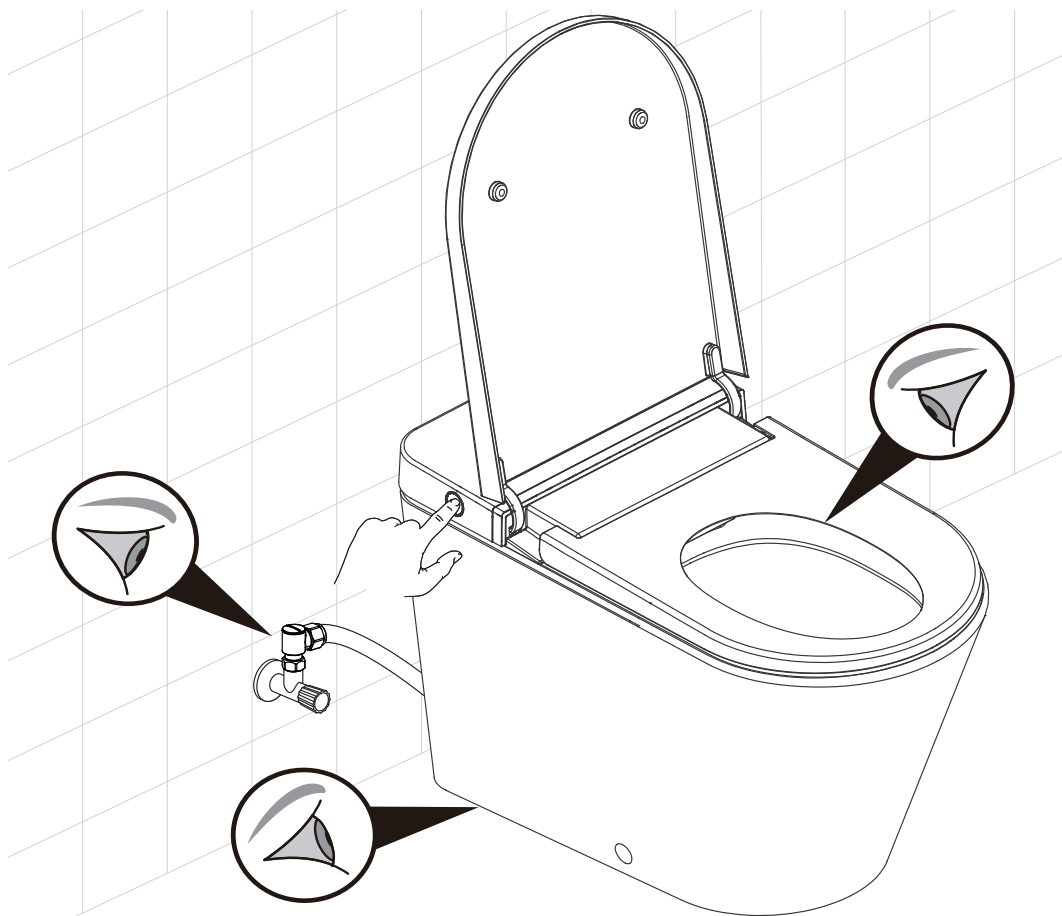

OPERATION AND MAINTENANCE

FLUSH

Press Flush button on the right hand side of the toilet.

SURFACE CLEANING

This product has been designed and manufactured with great care and attention to detail. If you follow a few simple cleaning instructions you will be able to enjoy its comfort, quality and beauty for many years to come.

CLEANING INSTRUCTIONS SEAT, LID AND BACK COVER

Use a mild soap solution to clean the seat and please take care that the seat and hinges are not left damp. Dry off any residual water or cleaning agents with a soft cloth. Avoid contact of the seat and hinges with abrasive, corrosive or chlorine-based cleaners, as these may cause damage or lead to flash rust. When cleaning the bowl, make sure that the seat and cover are kept in an upright position until all cleaning agent has been flushed away.

CLEANING INSTRUCTIONS CERAMIC

Under no circumstances should you use harsh or abrasive cleaning substances such as abrasive cream cleansers, scouring powder or drain cleaner on your ceramic surfaces. Also avoid using steam cleaners and hard, abrasive sponges.

The use of acidic cleaners with a pH value between 1 and 4 is highly recommended. Cleaners with a pH value in the neutral range (5 to 8) are not always suitable. We strongly advise against using either weak or strong alkaline cleaners, i.e. substances with pH values from 9 to 12.

FILTER CLEANING

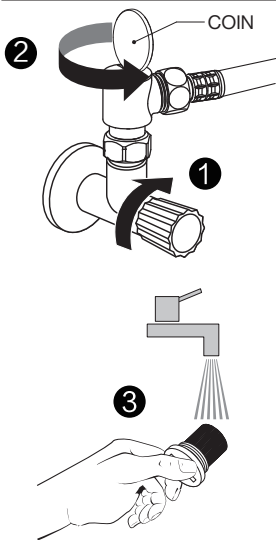

The intake filter may be detached and cleaned with soap and water as shown on the left.



When the water flow is less than normal, please clean the filter. Assure that the angle valve is shut off during cleaning.

Please put the filter back in reversed sequence after cleaning it.

TROUBLESHOOTING

FREQUENTLY ASKED QUESTIONS

IN CASE OF MINOR MALFUNCTIONS, PLEASE REFER TO THE FOLLOWING TABLE. IF THE BELOW SOLUTIONS DO NOT RESOLVE THE ISSUE, PLEASE CONTACT CUSTOMER SUPPORT FOR FURTHER EXAMINATION AND REPAIR.

Malfunction	Cause	Remedy
Leaking	Connection loose	Check connection between hose and main and tighten it.
No Flush	Water Supply Issue	Check water supply for abnormality and ensure supply valve is on.
Low Flush Volume	Low water pressure	Please ensure the water pressure over 20 psi.
	Slow refill time	Please waiting for 50 sec. for store water after last flush.

REPLACEMENT PARTS LIST

There will be instructions with the new replacement part.

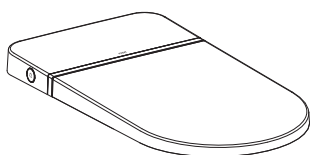

Seat Cover

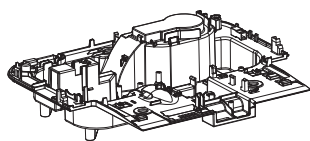

Base

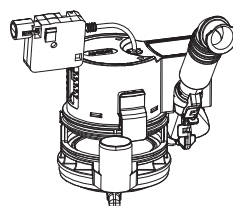

Flush Valve

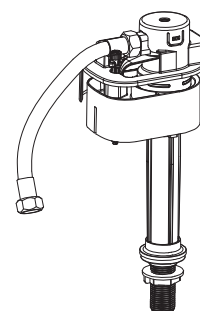

Fill Valve

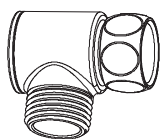

Filter

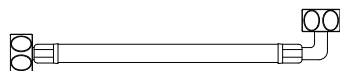

Inlet Hose-set



Fill Valve Diaphragm Seal

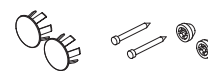

Bowl Mounting Hardware / Plug

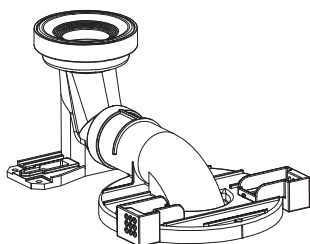

12" Flange

TECHINCAL DATA

Flow Pressure Range	0.14 - 0.69 MPa (20 - 100 psi)
Ambient Temperature Range	4 - 40 °C (+39 °F to + 104 °F)
Water Consumption	4.8 L (1.28 GPF)
Flush type	Vacuum V Flush
Net Weight	43 kg (95 lbs)
Product Dimension (L × B × H)	725 × 386 × 457 mm (28 ³ / ₁₆ × 15 ³ / ₁₆ × 18 inches)
Load Seat and Lid (Maximum)	150 kg (330 lbs)

LEGAL DIRECTIONS

This manual contains important information on the intended use, correct operation and proper maintenance of the equipment. Knowledge of and compliance with the instructions of this manual are provided for both the safe use of the equipment and for the safety of its operation and maintenance. In this manual, not all kinds of applications and improper manipulations are considered. In addition, attention is drawn to the following: The content of these instructions is neither part of any previous or existing agreement, commitment or legal relationship, nor does it change from an existing agreement, commitment or legal relationship. Any commitment by AXENT results from the respective warranty. These include the complete and authoritative warranty obligation AXENT. The statements in this manual do not constitute an extension or a restriction of the claims under the warranty provisions. This manual is protected by copyright. Copies and / or translations into other languages may be made only with prior written approval of AXENT.

GUARANTEE

Thank you for selecting our AXENT Switzerland. To ensure that your installation proceeds smoothly, please follow these instructions carefully before you begin. Carefully unpack and examine the item before beginning installation.

ALL INSTALLATION PROCEDURES MUST COMPLY IN STRICT ACCORDANCE WITH APPLICABLE LOCAL PLUMBING AND BUILDING CODES.

PROFESSIONAL LICENSED PLUMBER / CONTRACTOR HIGHLY RECOMMENDED FOR INSTALLATION.

THANK YOU FOR CHOOSING

We appreciate your commitment to AXENT Switzerland. If you encounter any installation or performance problems, please don't hesitate to contact us at 1-800-769-4857.

Thanks again for choosing AXENT Switzerland.

BEFORE YOU BEGIN



CAUTION!

Risk of personal injury or product damage

Handle with care. Vitreous china can break or chip if the product is handled carelessly. Observe all local plumbing and building codes.

CARE AND CLEANING



DO NOT USE IN-TANK BOWL CLEANERS.

The use of high concentration of chlorine or chlorine-related products can seriously damage fittings in the tank. This damage can cause leakage and property damage. AXENT Switzerland shall not be responsible or liable for any tank fitting failure or damage caused by the use of in-tank bowl cleaners.

AXENT LIMITED WARRANTY

AXENT provides you with a ONE-YEAR LIMITED PARTS WARRANTY. This is to guarantee that your newly purchased AXENT product is free from defects in materials and workmanship during normal use when properly installed, serviced and maintained. This warranty is available only to the original purchaser and is not transferable. Proof of purchase is required to show that you are the original purchaser. The warranty is good for one-year from the date of purchase and applies to AXENT products purchased and installed in North America from an AXENT authorized dealers.

AXENT's warranty is limited to repair, replace or make appropriate adjustments at AXENT's sole discretion to properly bring the product back to normal operating function. AXENT reserves the right to perform inspection to the product to properly determine the cause of the defect. AXENT will not be responsible for any labor cost associated with the warranty repair, replacement or adjustment as the warranty only covers parts. AXENT is not responsible for the cost of removal, return and/or re-installation.

This warranty does not apply to the following times.

1. Damage or loss resulting from any misuse, abuse, negligence, improper care, cleaning and maintenance of the product.
2. Damage or loss as a result of using in-tank toilet cleaners.
3. Damages or loss sustained in natural calamity such as fire, earthquake, flood, thunder, electrical storm, etc.
4. Damage or loss resulting from sediments or foreign matter contained in a water system
5. Damage or loss resulting from improper storage, handling, installation or repair of the product.
6. Damage or loss resulting from electrical surges or lightning strikes or other acts or events not caused by or is the fault of AXENT.
7. Damage or loss resulting from normal use, wear and tear. Scratches, fading, reducing of gloss, thinning out of coating over time, etc are all considered wear and tear.

To obtain further information or report a claim, please contact the Axent Customer Service Department at 1-800-769-4857 or write us at support@axentproducts.com or 3 Musick Irvine, CA 92618.

AXENT Corporation Ltd.

www.axentbath.us
support@axentproducts.com
1-800-769-4857